

Write your name here

Surname

Other names

Centre Number

Candidate Number

Edexcel GCSE

Mathematics A

Paper 1 (Non-Calculator)

Foundation Tier

Thursday 28 February 2013 – Afternoon

Time: 1 hour 45 minutes

Paper Reference

1MA0/1F

You must have: Ruler graduated in centimetres and millimetres, protractor, pair of compasses, pen, HB pencil, eraser. Tracing paper may be used.

Total Marks

Instructions

- Use **black** ink or ball-point pen.
- **Fill in the boxes** at the top of this page with your name, centre number and candidate number.
- Answer **all** questions.
- Answer the questions in the spaces provided – *there may be more space than you need.*
- **Calculators must not be used.**



Information

- The total mark for this paper is 100
- The marks for **each** question are shown in brackets – *use this as a guide as to how much time to spend on each question.*
- Questions labelled with an **asterisk** (*) are ones where the quality of your written communication will be assessed.

Advice

- Read each question carefully before you start to answer it.
- Keep an eye on the time.
- Try to answer every question.
- Check your answers if you have time at the end.

Turn over ►

P42056A

©2013 Pearson Education Ltd.

6/7/4/1/



P 4 2 0 5 6 A 0 1 2 8

PEARSON

GCSE Mathematics 1MA0

Formulae: Foundation Tier

**You must not write on this formulae page.
Anything you write on this formulae page will gain NO credit.**

Area of trapezium = $\frac{1}{2}(a + b)h$



Volume of prism = area of cross section \times length

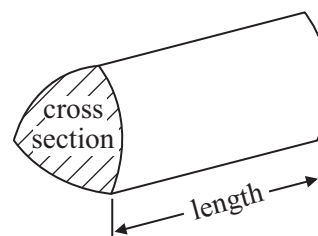

Answer ALL questions.

Write your answers in the spaces provided.

You must write down all stages in your working.

You must NOT use a calculator.

- 1** The pictogram shows the numbers of zips sold in a shop on Monday, on Tuesday and on Wednesday.

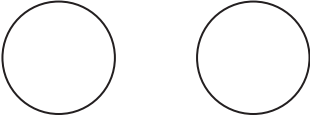
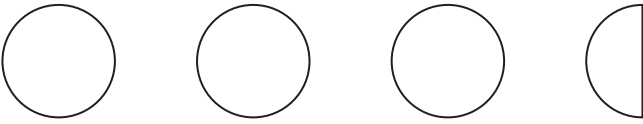
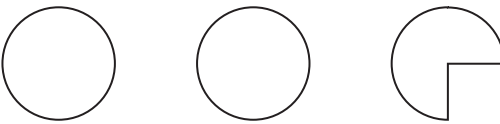
Monday	
Tuesday	
Wednesday	
Thursday	

Key:

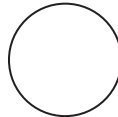

represents 4 zips

- (a) Write down the number of zips sold on Monday.

.....
(1)

- (b) Write down the number of zips sold on Wednesday.

.....
(1)

9 zips were sold on Thursday.

- (c) Complete the pictogram.

(1)

(Total for Question 1 is 3 marks)



P 4 2 0 5 6 A 0 3 2 8

2

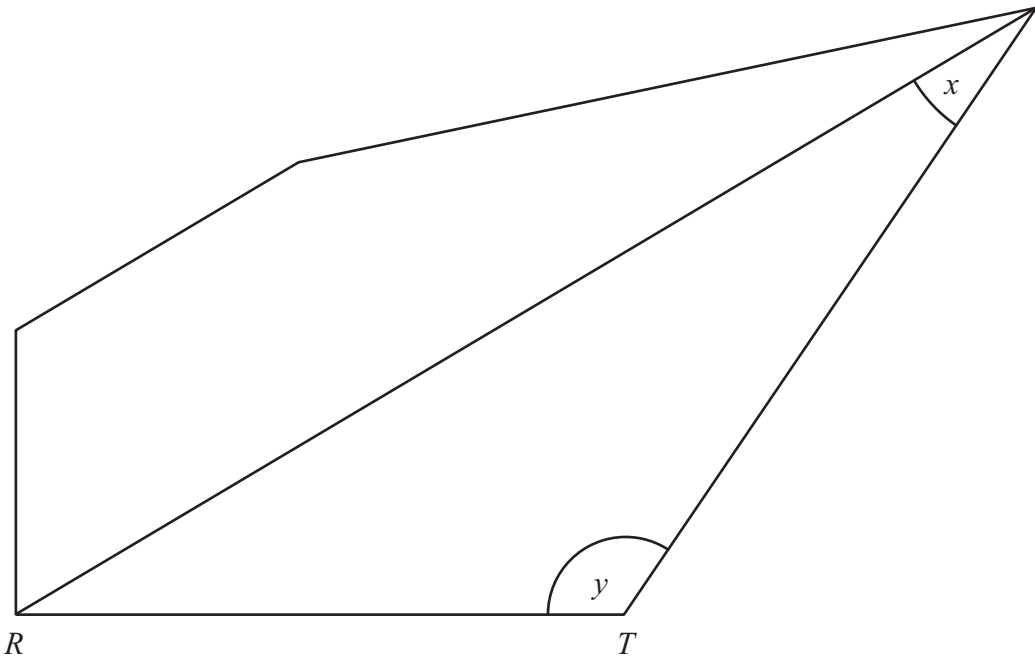

(a) Mark with arrows (\gg) a pair of parallel lines.

(1)

(b) Measure the length of the line RT .

..... cm

(1)

(c) What type of angle is angle x ?

.....

(1)

(d) Measure the size of angle y .

.....^o

(1)

(Total for Question 2 is 4 marks)



- 3 (a) Write these numbers in order of size.
Start with the smallest number.

358 835 709 98 145

.....
(1)

- (b) Write these numbers in order of size.
Start with the smallest number.

4 -5 7 -1 -8

.....
(1)

- (c) Write these numbers in order of size.
Start with the smallest number.

$\frac{1}{4}$ 0.2 40% $\frac{3}{4}$ 0.5

.....
(2)

(Total for Question 3 is 4 marks)



4 Liam throws a fair coin once.

(a) On the probability scale below, mark with a cross (×) the probability that he gets a head.

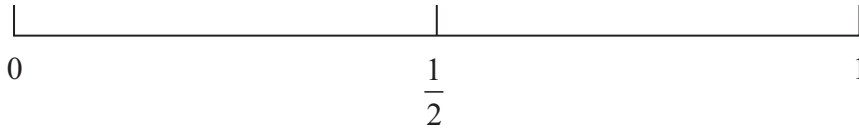

(1)

Ann rolls a fair dice once.

(b) On the probability scale below, mark with a cross (×) the probability that she gets a 7

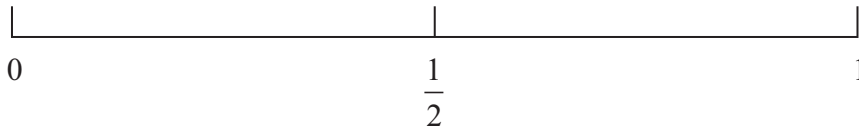

(1)

Fred throws a fair coin and rolls a fair dice.

(c) (i) List all the possible combinations.
The first one has been done for you.

(H, 1).....
.....
.....

(ii) Write down the probability that Fred gets a head and an even number.

.....
(4)

(Total for Question 4 is 6 marks)



*5 Sarah wants to buy some fruit.

She wants to buy

3 oranges at 30p each

and $\frac{1}{2}$ kg apples at £1.20 per kg.

The only money Sarah has is one 50p coin and six 20p coins.

She pays for the fruit.

Work out how much money Sarah has left.

You must show all your working.

(Total for Question 5 is 5 marks)



6 Here is a square.

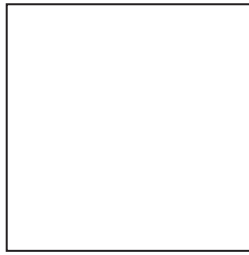

(a) On the square, draw all the lines of symmetry.

(2)

Here is a rectangle.

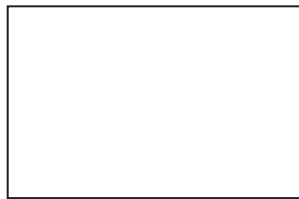

(b) Write down the order of rotational symmetry of the rectangle.

.....
(1)

Here is a different rectangle.

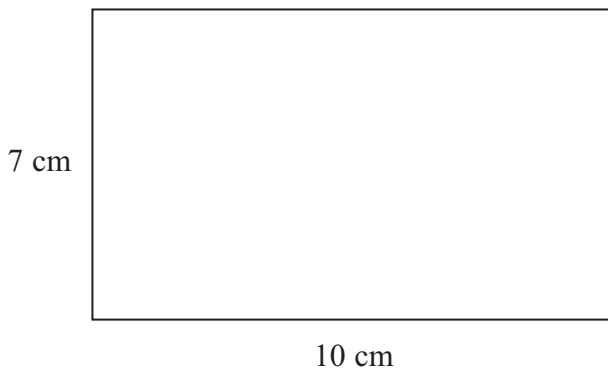

Diagram **NOT**
accurately drawn

(c) Work out the area of this rectangle.

..... cm²
(2)

(Total for Question 6 is 5 marks)



7 Mrs Smith gave her students a history test.

The bar chart shows information about the students' marks.

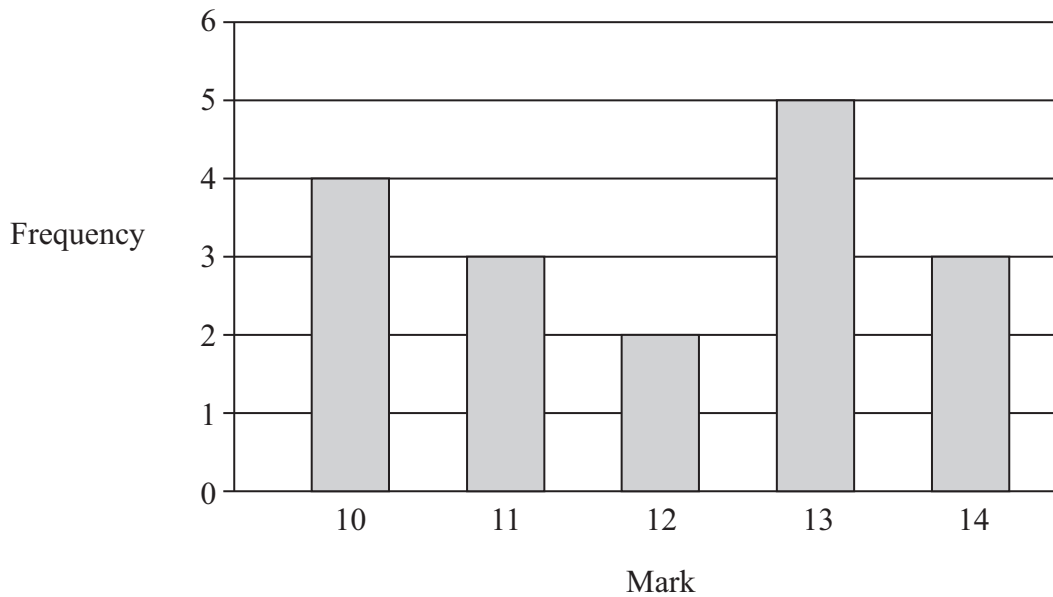

(a) Write down the number of students who got 10 marks.

.....
(1)

(b) Write down the mode.

.....
(1)

(c) Which two marks have the same frequency?

..... and

(1)

(d) Work out the range.

.....
(2)

(e) How many students did the test?

.....
(2)

(Total for Question 7 is 7 marks)



8 (a) Write 8 45 pm as a 24-hour clock time.

.....
(1)

Seeta did a puzzle in 3 minutes 45 seconds.

Ninal did the same puzzle in 7 minutes 28 seconds.

Seeta says,

‘I did the puzzle in less than half the time Ninal did the puzzle.’

*(b) Is Seeta right?

You must show all your working.

(3)

(Total for Question 8 is 4 marks)



9 (a) Simplify $a + a + a + a$

.....
(1)

(b) Simplify $3 \times c \times d$

.....
(1)

(c) Simplify $3ef + 5ef - ef$

.....
(1)

(d) Solve $6g = 18$

$g =$
(1)

(e) Solve $5h + 7 = 17$

$h =$
(2)

(Total for Question 9 is 6 marks)



10 Here are a quadrilateral and a triangle drawn on a centimetre grid.

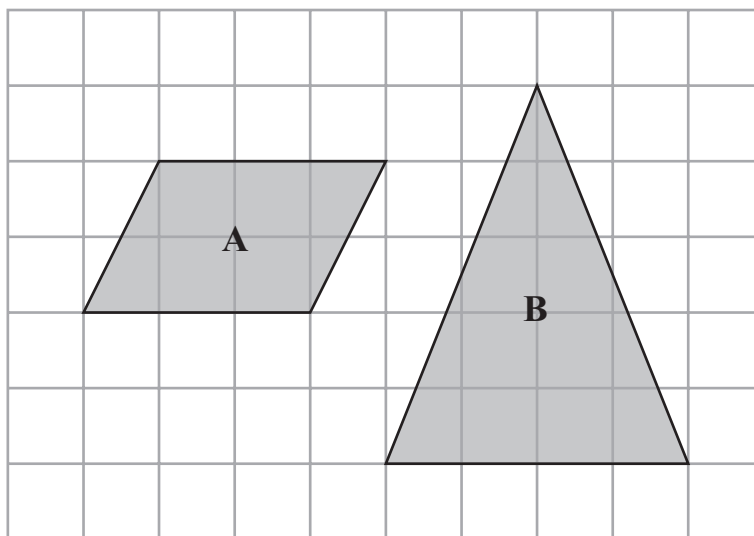

(a) Write down the special name for quadrilateral **A**.

.....
(1)

(b) Write down the special name for triangle **B**.

.....
(1)

(c) Find the area of quadrilateral **A**.

..... cm²
(2)

(Total for Question 10 is 4 marks)



11

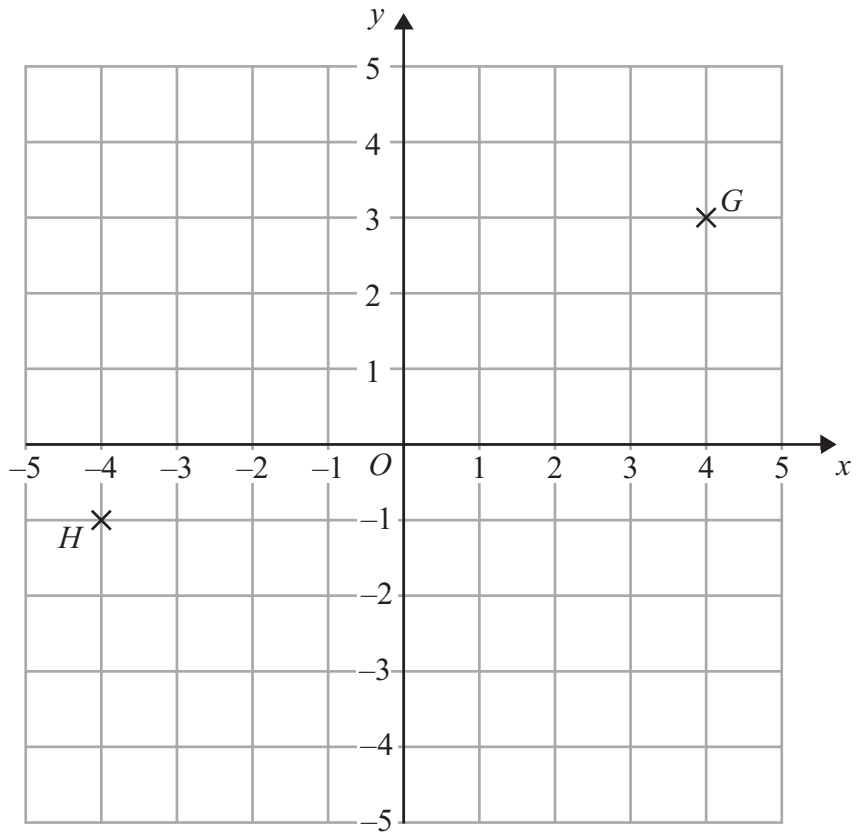

(a) (i) Write down the coordinates of the point G .

(..... ,)

(ii) Write down the coordinates of the point H .

(..... ,)
(2)

(b) Find the coordinates of the midpoint of GH .

(..... ,)
(2)

(Total for Question 11 is 4 marks)



12

mirror
line

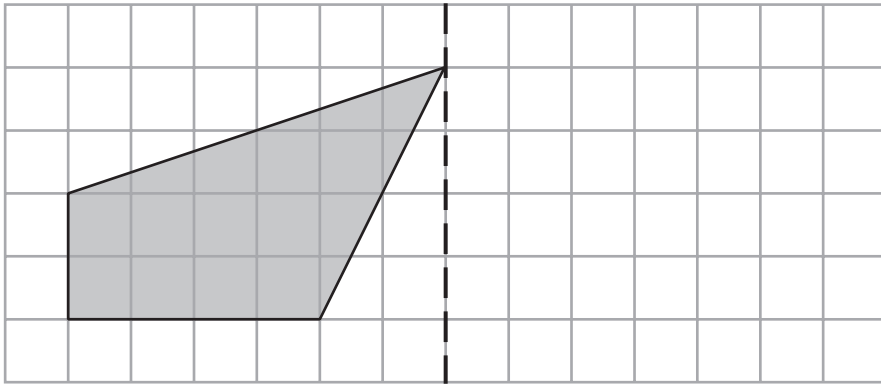

(a) Reflect the shaded shape in the mirror line.

(2)

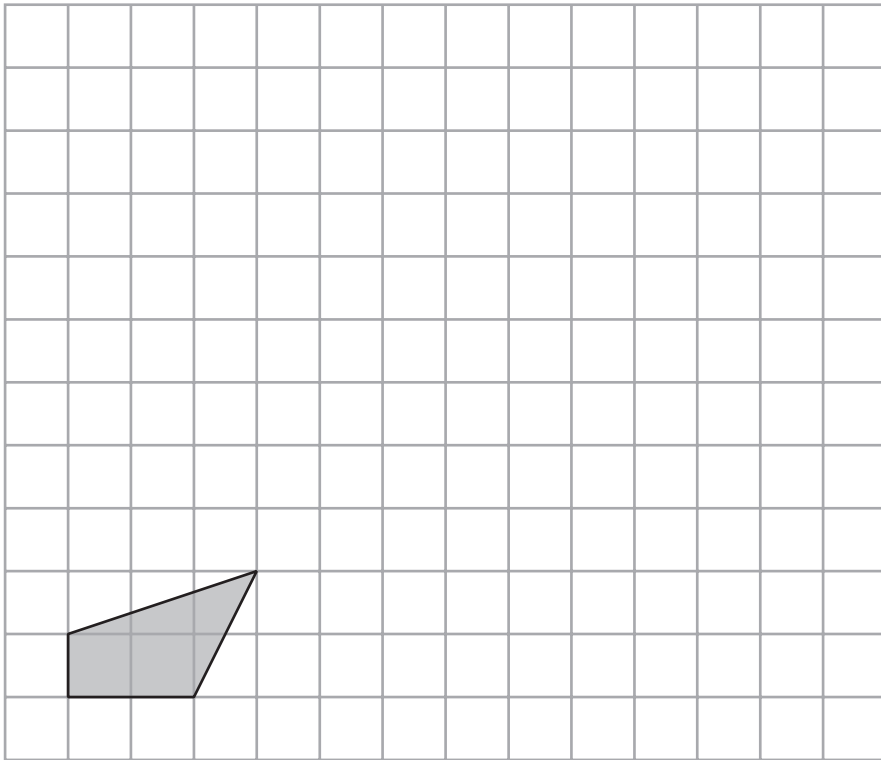

(b) On the grid, enlarge the shaded shape using a scale factor of 3

(2)



Here is a different shape.

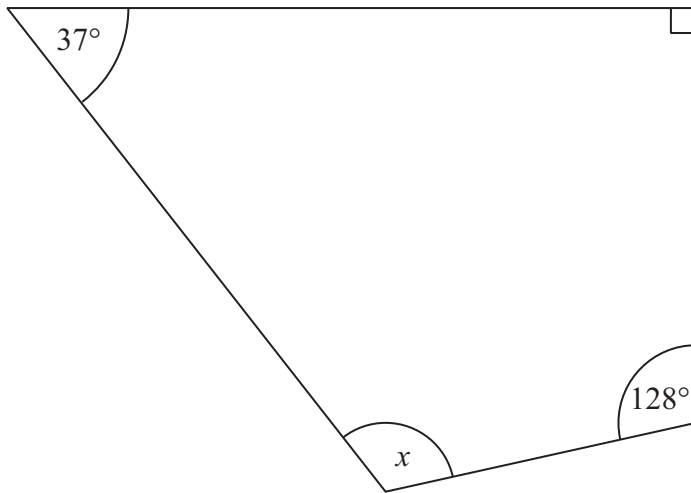

Diagram **NOT**
accurately drawn

(c) Work out the size of angle x .

.....
(2)

(Total for Question 12 is 6 marks)



13 You can use this rule to work out the total cost of hiring a car.

$$\text{Total cost} = \text{£4 per hour plus £12}$$

Arun hires a car for 5 hours.

(a) Work out the total cost.

£
(2)

Raj hires a car.
The total cost is £40

(b) Work out how many hours Raj hires the car for.

..... hours
(3)

(Total for Question 13 is 5 marks)



14 You can use this conversion graph to change between pounds (£) and dollars (\$).

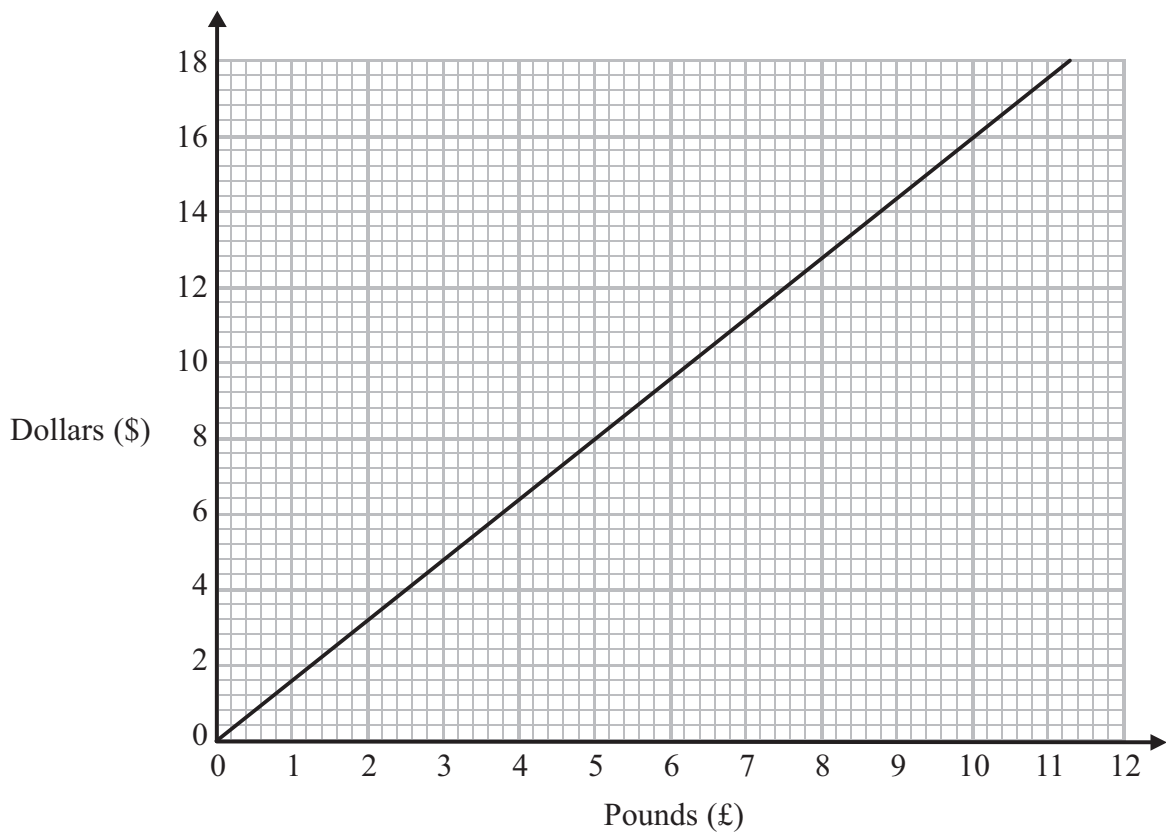

(a) Use the conversion graph to change £5 to dollars.

\$
(1)

Ella has \$200 and £800
Her hotel bill is \$600

Ella pays the bill with the \$200 and some of the pounds.

(b) Use the conversion graph to work out how many pounds she has left.

£
(4)

(Total for Question 14 is 5 marks)



15 Here is a list of numbers.

1 2 4 5 7 11 13 14 15 17

From the list, write down **three different** prime numbers that add together to make 20

.....
(Total for Question 15 is 3 marks)

16 Trams leave Piccadilly

to Eccles every 9 minutes

to Didsbury every 12 minutes

A tram to Eccles and a tram to Didsbury both leave Piccadilly at 9 am.

At what time will a tram to Eccles and a tram to Didsbury next leave Piccadilly at the same time?

.....
(Total for Question 16 is 3 marks)



17 Zuber wants to find out the colours of cars in a car park.

Design a suitable table for a data collection sheet he could use.

(Total for Question 17 is 3 marks)



*18

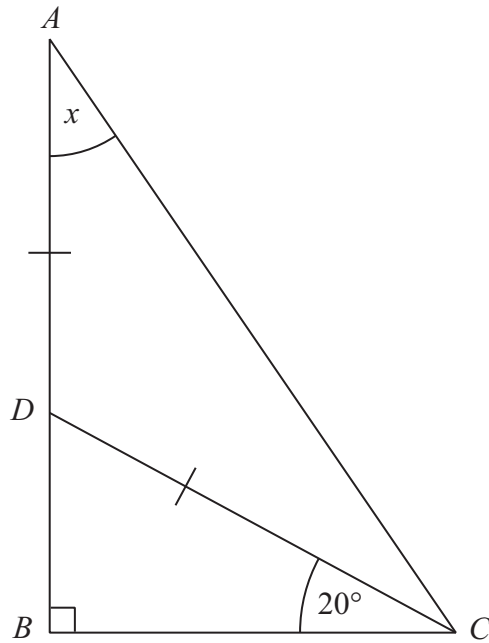

Diagram **NOT**
accurately drawn

Triangle ABC is a right-angled triangle.
 ADB is a straight line.
 $DA = DC$
Angle $BCD = 20^\circ$

Work out the size of the angle marked x .
You must give reasons for each stage of your working.

(Total for Question 18 is 4 marks)



19 Work out 1.83×47

.....
(Total for Question 19 is 3 marks)



20 Paula wants to find out how much money people spend buying CDs.

She uses this question on a questionnaire.

How much money do you spend buying CDs?

£10 – £30 £30 – £50 £50 – £70 more than £70

(a) Write down **two** things wrong with this question.

1

2

(2)

Paula asks 100 people in a CD store to do her questionnaire.

(b) Her sample is biased.
Explain why.

.....

(1)

(Total for Question 20 is 3 marks)



21 Here is a scale drawing of a rectangular garden $ABCD$.



Scale: 1 cm represents 1 metre.

Jane wants to plant a tree in the garden
at least 5 m from point C ,
nearer to AB than to AD
and less than 3 m from DC .

On the diagram, shade the region where Jane can plant the tree.

(Total for Question 21 is 4 marks)



22 Greg sells car insurance and home insurance.

The table shows the cost of these insurances.

Insurance	car insurance	home insurance
Cost	£200	£350

Each month Greg earns

£530 basic pay
5% of the cost of all the car insurance he sells
and 10% of the cost of all the home insurance he sells

In May Greg sold

6 car insurances
and 4 home insurances

Work out the total amount of money Greg earned in May.



£

(Total for Question 22 is 5 marks)



23 5 schools sent some students to a conference.

One of the schools sent both boys and girls.

This school sent 16 boys.

The ratio of the number of boys it sent to the number of girls it sent was 1 : 2

The other 4 schools sent only girls.

Each of the 5 schools sent the same number of students.

Work out the total number of students sent to the conference by these 5 schools.

.....
(Total for Question 23 is 4 marks)

TOTAL FOR PAPER IS 100 MARKS



BLANK PAGE



BLANK PAGE

