

Write your name here

Surname

Other names

Pearson
Edexcel GCSE

Centre Number

--	--	--	--	--

Candidate Number

--	--	--	--

Mathematics A

Paper 1 (Non-Calculator)

Higher Tier

Thursday 4 June 2015 – Morning

Time: 1 hour 45 minutes

Paper Reference

1MA0/1H

You must have: Ruler graduated in centimetres and millimetres, protractor, pair of compasses, pen, HB pencil, eraser. Tracing paper may be used.

Total Marks



Instructions

- Use **black** ink or ball-point pen.
- **Fill in the boxes** at the top of this page with your name, centre number and candidate number.
- Answer **all** questions.
- Answer the questions in the spaces provided – *there may be more space than you need.*
- **Calculators must not be used.**

Information

- The total mark for this paper is 100
- The marks for **each** question are shown in brackets – *use this as a guide as to how much time to spend on each question.*
- Questions labelled with an **asterisk** (*) are ones where the quality of your written communication will be assessed.

Advice

- Read each question carefully before you start to answer it.
- Keep an eye on the time.
- Try to answer every question.
- Check your answers if you have time at the end.

Turn over ►

P45870A

©2015 Pearson Education Ltd.

6/6/6/8/



PEARSON

GCSE Mathematics 1MA0

Formulae: Higher Tier

**You must not write on this formulae page.
Anything you write on this formulae page will gain NO credit.**

Volume of prism = area of cross section \times length

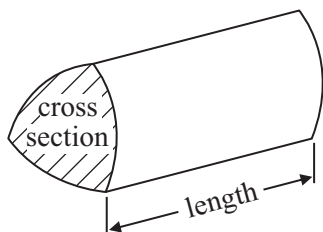

Area of trapezium = $\frac{1}{2} (a + b)h$

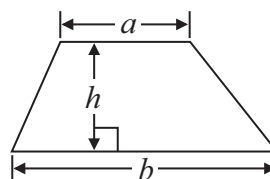

Volume of sphere = $\frac{4}{3} \pi r^3$

Surface area of sphere = $4\pi r^2$

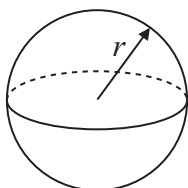

Volume of cone = $\frac{1}{3} \pi r^2 h$

Curved surface area of cone = $\pi r l$

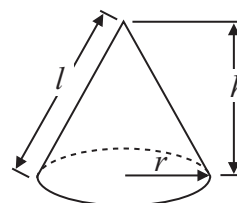

In any triangle ABC

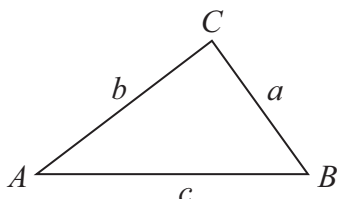

The Quadratic Equation

The solutions of $ax^2 + bx + c = 0$
where $a \neq 0$, are given by

$$x = \frac{-b \pm \sqrt{b^2 - 4ac}}{2a}$$

Sine Rule $\frac{a}{\sin A} = \frac{b}{\sin B} = \frac{c}{\sin C}$

Cosine Rule $a^2 = b^2 + c^2 - 2bc \cos A$

Area of triangle = $\frac{1}{2} ab \sin C$



Answer ALL questions.

Write your answers in the spaces provided.

You must write down all stages in your working.

You must NOT use a calculator.

1 Here are the heights in centimetres of 20 men.

165 164 176 179 188 178 183 172 180 190

167 159 156 176 173 168 169 182 167 192

(a) Show this information in an ordered stem and leaf diagram.

(3)

(b) Work out the percentage of these men with a height greater than 184 cm.

..... %

(2)

(Total for Question 1 is 5 marks)



2 $x = 3$

(a) Work out the value of $4x^2$

.....
(1)

(b) Solve $5x + 4 = 14 + x$

$x =$
(2)

(Total for Question 2 is 3 marks)

3 Sean works for a town council.

He wants to find out how often people use the BMX track in the town.

He is going to use a questionnaire.

Design a suitable question for Sean to use in his questionnaire.

(Total for Question 3 is 2 marks)



*4 Tom is going to buy 25 plants to make a hedge.

Here is information about the cost of buying the plants.

<p>Kirsty's Plants</p> <p>£2.39 each</p>

<p>Hedge World</p> <p>Pack of 25</p> <p>£52.50 plus VAT at 20%</p>

Tom wants to buy the 25 plants as cheaply as possible.

Should Tom buy the plants from Kirsty's Plants or from Hedge World?

You must show all your working.

(Total for Question 4 is 5 marks)



5 Jane makes cheese.

The cheese is in the shape of a cuboid.

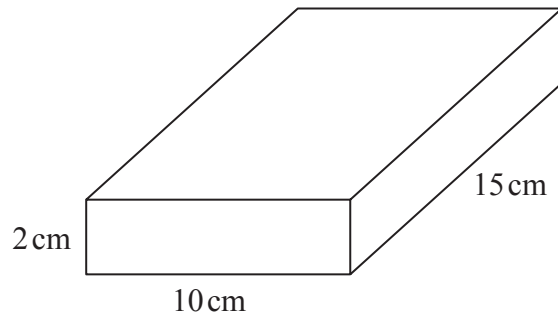

Diagram **NOT** accurately drawn

Jane is going to make a new cheese.

The new cheese will also be in the shape of a cuboid.

The cross section of the cuboid will be a 5 cm by 5 cm square.

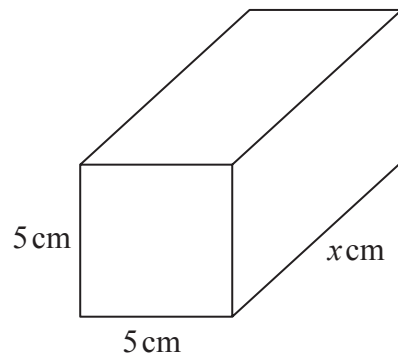

Diagram **NOT** accurately drawn

Jane wants the new cuboid to have the same volume as the 2 cm by 10 cm by 15 cm cuboid.

Work out the value of x .

(Total for Question 5 is 3 marks)



- 6 The scatter graph shows information about the age and the price of each of 12 cars of the same model.

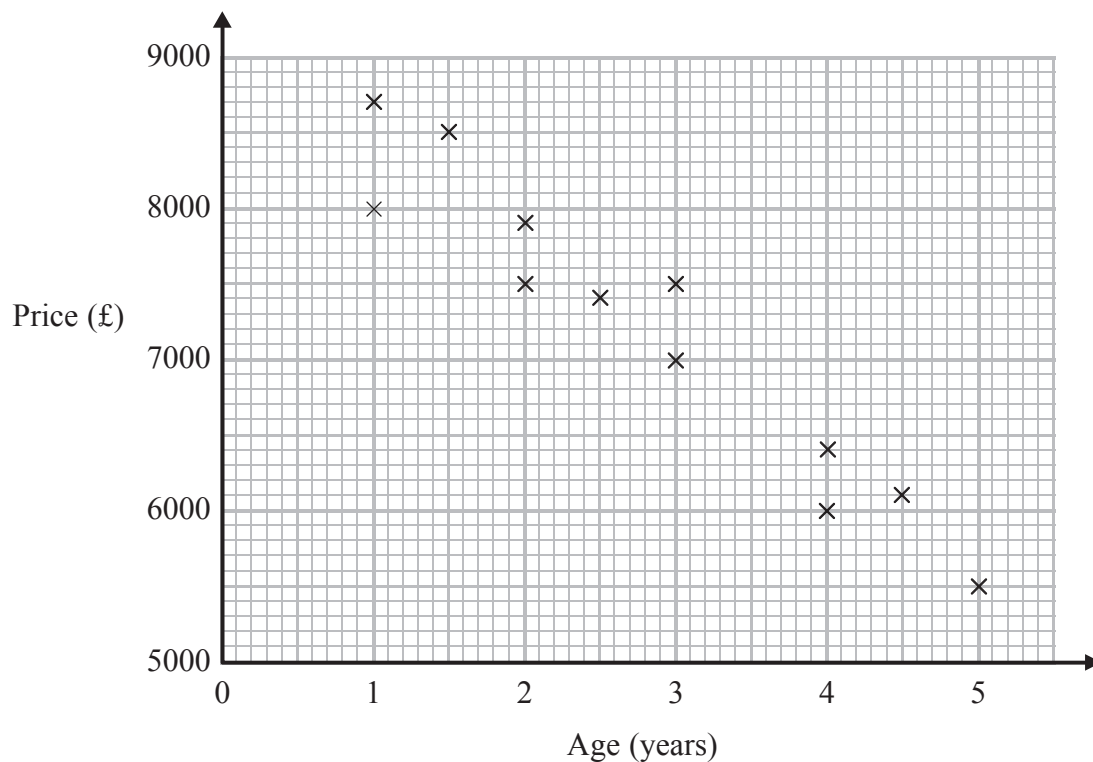

- (a) Describe the relationship between the age of a car and its price.

(1)

A different car of the same model is $3\frac{1}{2}$ years old.

- (b) Estimate the price of this car.

£.....

(2)

(Total for Question 6 is 3 marks)



7

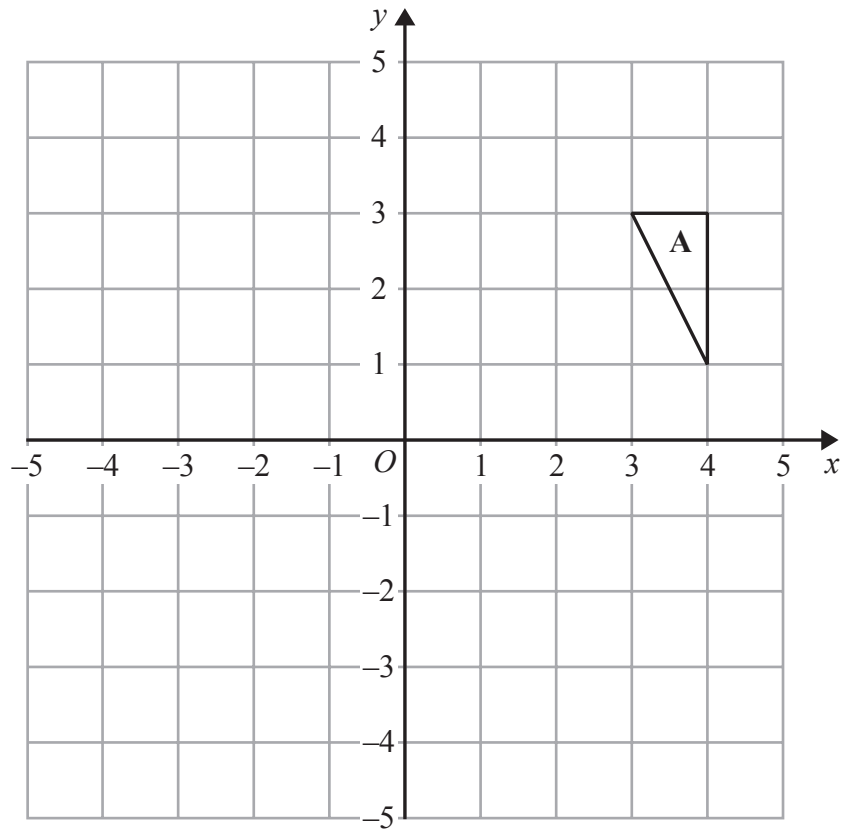

(a) Rotate triangle A 90° anticlockwise with centre O.

(2)



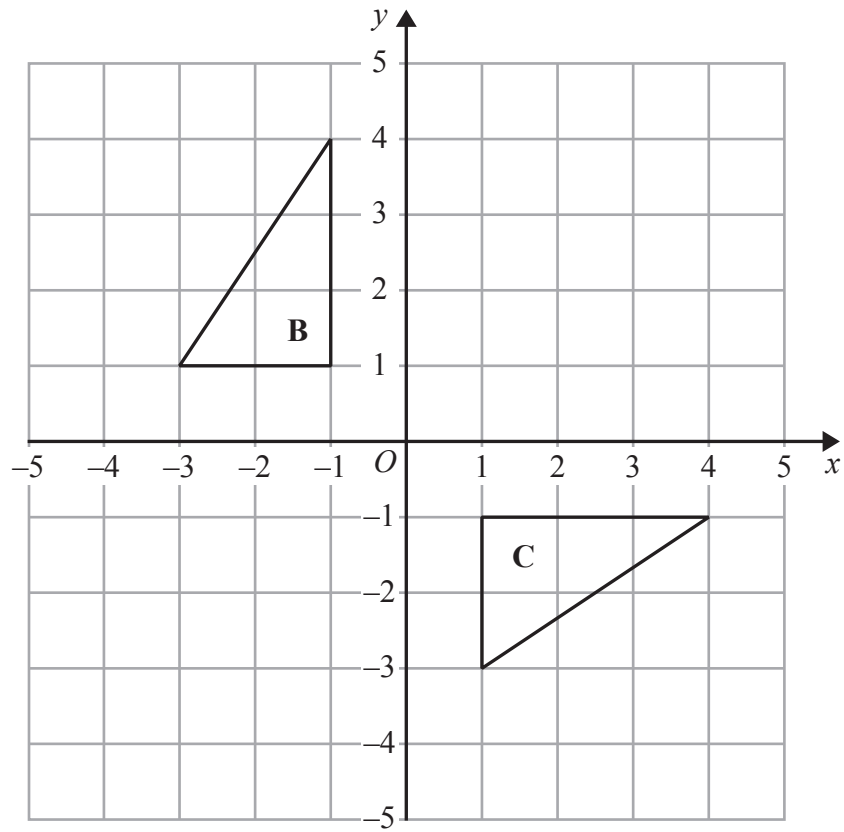

(b) Describe fully the single transformation that maps triangle **B** onto triangle **C**.

.....

.....

(2)

(Total for Question 7 is 4 marks)



8 (a) Simplify $6g - 5h - 4g + 2h$

.....
(2)

(b) Factorise $y^2 - 2y$

.....
(1)

(c) Simplify fully $\frac{p^3 \times p^4}{p^2}$

.....
(2)

(Total for Question 8 is 5 marks)



9 John buys some boxes of pencils and some packets of pens for people to use at a conference.

There are 40 pencils in a box.

There are 15 pens in a packet.

John gives one pencil and one pen to each person at the conference.

He has no pencils left.

He has no pens left.

How many boxes of pencils and how many packets of pens did John buy?

..... boxes of pencils

..... packets of pens

(Total for Question 9 is 3 marks)



*10 The diagram shows the floor plan of Mary's conservatory.

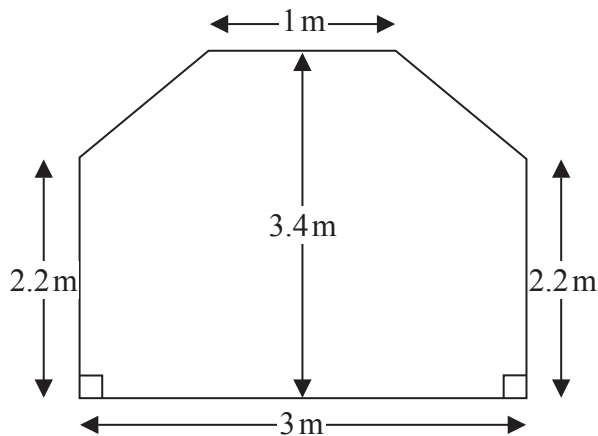

Diagram **NOT**
accurately drawn

Mary is going to cover the floor with tiles.

The tiles are sold in packs.

One pack of tiles will cover 2 m^2

A pack of tiles normally costs £24.80

Mary gets a discount of 25% off the cost of the tiles.

Mary has £100

Does Mary have enough money to buy all the tiles she needs?

You must show all your working.

(Total for Question 10 is 5 marks)



11 Karl wants to raise money for charity.
He designs a game for people to play.

Karl uses a fair 10-sided dice for the game.
The dice is numbered from 1 to 10

Each person will roll the dice once.
A person wins the game if the dice lands on a multiple of 4

Ali plays the game once.

(a) Work out the probability that Ali will win the game.

.....
(2)

Each person pays 30p to play the game once.
The prize for a win is £1

Karl thinks that the game will be played 100 times.

(b) Work out an estimate for how much money Karl will raise for charity.

.....
(3)

(Total for Question 11 is 5 marks)



*12

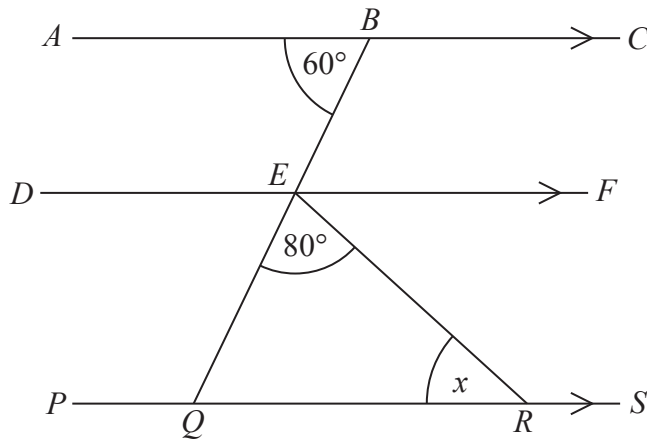

Diagram **NOT**
accurately drawn

ABC , DEF and $PQRS$ are parallel lines.
 BEQ is a straight line.

Angle $ABE = 60^\circ$

Angle $QER = 80^\circ$

Work out the size of the angle marked x .

Give reasons for each stage of your working.

(Total for Question 12 is 4 marks)



13 Here is a rectangle.

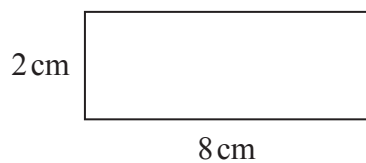

Diagram **NOT**
accurately drawn

The 8-sided shape below is made from 4 of these rectangles and 4 congruent right-angled triangles.

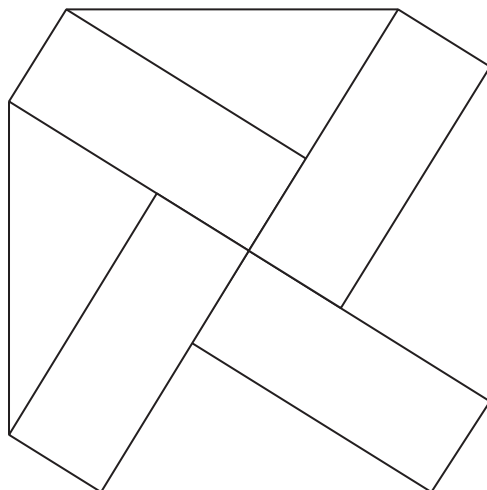

Diagram **NOT**
accurately drawn

Work out the perimeter of the 8-sided shape.
You must show all your working.

..... cm

(Total for Question 13 is 5 marks)



- 14 The distance from Fulbeck to Ganby is 10 miles.
The distance from Ganby to Horton is 18 miles.



Raksha is going to drive from Fulbeck to Ganby.
Then she will drive from Ganby to Horton.

Raksha leaves Fulbeck at 10 00
She drives from Fulbeck to Ganby at an average speed of 40 mph.

Raksha wants to get to Horton at 10 35

Work out the average speed Raksha must drive at from Ganby to Horton.

..... mph

(Total for Question 14 is 3 marks)



15 A and B are two points.

Point A has coordinates $(-2, 4)$.

Point B has coordinates $(8, 9)$.

C is the midpoint of the line segment AB .

(a) Find the coordinates of C .

(.....,.....)
(2)

D is the point with coordinates $(100, 56)$.

*(b) Does point D lie on the straight line that passes through A and B ?
You must show how you work out your answer.

(3)

(Total for Question 15 is 5 marks)



16 The table shows information about the times taken by 100 people in a fun run.

Time (t minutes)	Frequency
$20 < t \leq 30$	4
$30 < t \leq 40$	16
$40 < t \leq 50$	36
$50 < t \leq 60$	24
$60 < t \leq 70$	14
$70 < t \leq 80$	6

(a) Complete the cumulative frequency table for this information.

Time (t minutes)	Cumulative frequency
$20 < t \leq 30$	
$20 < t \leq 40$	
$20 < t \leq 50$	
$20 < t \leq 60$	
$20 < t \leq 70$	
$20 < t \leq 80$	

(1)

(b) On the grid, draw a cumulative frequency graph for your table.

(2)



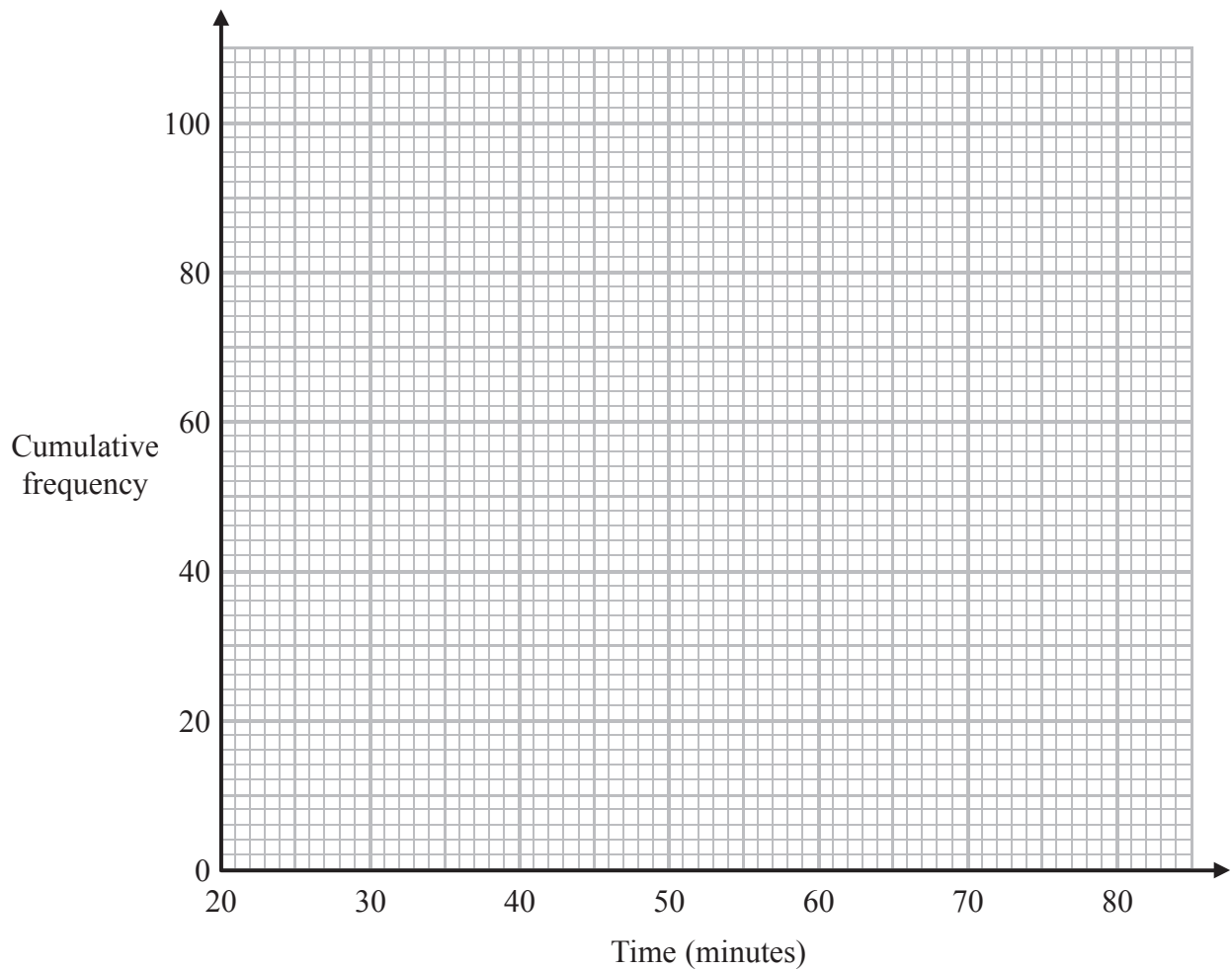

(c) Use your graph to find an estimate for the median time.

..... minutes
(1)

(d) Use your graph to find an estimate for the number of people who took longer than 63 minutes.

.....
(2)

(Total for Question 16 is 6 marks)



17

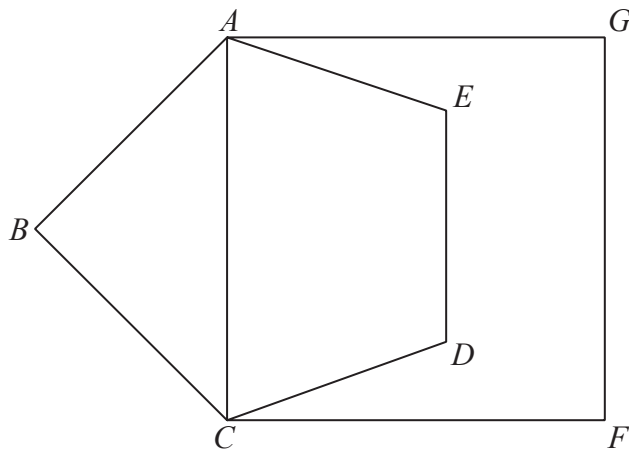

Diagram **NOT**
accurately drawn

$ABCDE$ is a regular pentagon.
 $ACFG$ is a square.

Work out the size of angle DCF .
You must show all your working.

(Total for Question 17 is 4 marks)



18 On the grid show, by shading, the region that satisfies all three of the inequalities

$$x + y < 7$$

$$y < 2x$$

$$y > 3$$

Label the region **R**.

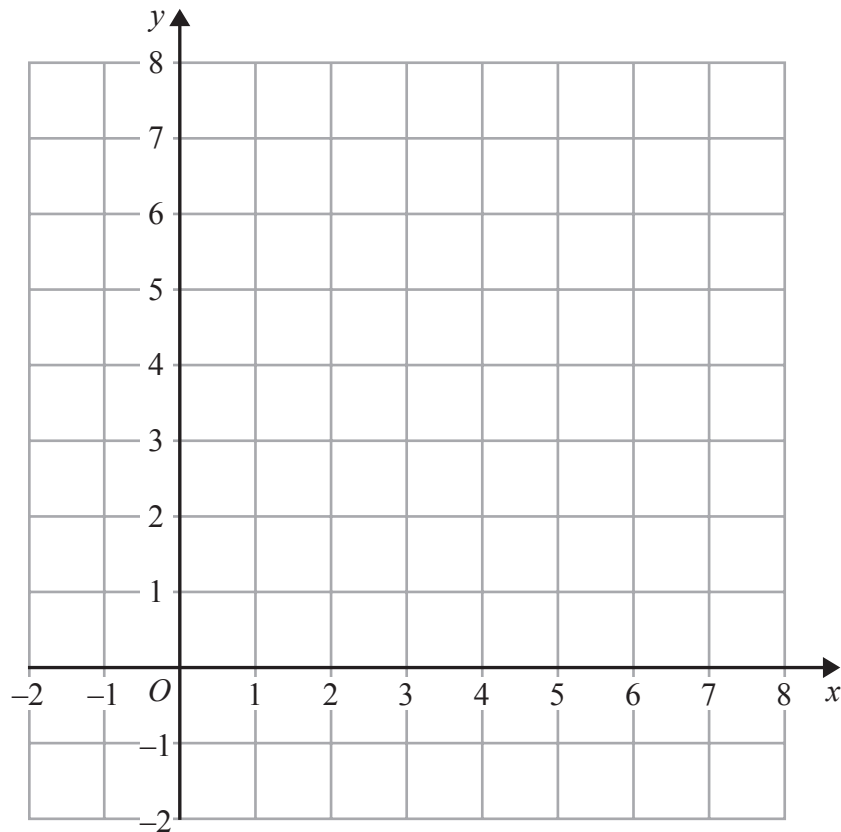

(Total for Question 18 is 4 marks)



- 19 There are n sweets in a bag.
6 of the sweets are orange.
The rest of the sweets are yellow.

Hannah takes at random a sweet from the bag.
She eats the sweet.

Hannah then takes at random another sweet from the bag.
She eats the sweet.

The probability that Hannah eats two orange sweets is $\frac{1}{3}$

- (a) Show that $n^2 - n - 90 = 0$

(3)

- (b) Solve $n^2 - n - 90 = 0$ to find the value of n .

.....
(3)

(Total for Question 19 is 6 marks)



20 Make a the subject of the formula $p = \frac{3a + 5}{4 - a}$

.....
(Total for Question 20 is 4 marks)



21 $x = 0.0\dot{4}\dot{5}$

Prove algebraically that x can be written as $\frac{1}{22}$

(Total for Question 21 is 3 marks)



22 (a) Find the value of 2^{-3}

.....
(1)

$5\sqrt{5}$ can be written in the form 5^k

(b) Find the value of k .

.....
(1)

(c) Work out the value of $(\sqrt{12} - \sqrt{3})^2$

.....
(2)

(Total for Question 22 is 4 marks)



23 The diagram shows a container for grain.

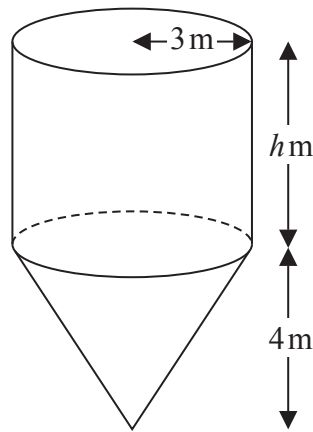

Diagram **NOT**
accurately drawn

The container is a cylinder on top of a cone.
The cylinder has a radius of 3 m and a height of h m.
The cone has a base radius of 3 m and a vertical height of 4 m.

The container is empty.
The container is then filled with grain at a constant rate.

After 5 hours the depth of the grain is 6 metres above the vertex of the cone.
After 9 hours the container is full of grain.

Work out the value of h .
Give your answer as a fraction in its simplest form.
You must show all your working.

(Total for Question 23 is 5 marks)



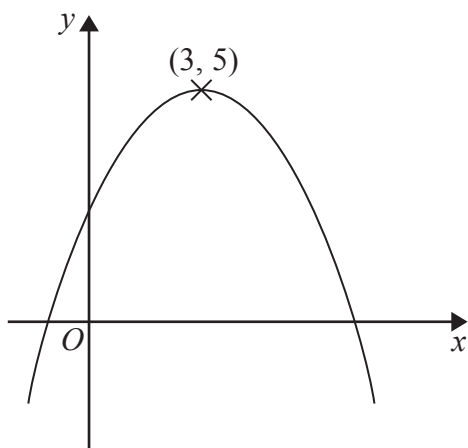

The diagram shows part of the curve with equation $y = f(x)$.
 The coordinates of the maximum point of the curve are $(3, 5)$.

(a) Write down the coordinates of the maximum point of the curve with equation

(i) $y = f(x + 3)$

(.....,) (1)

(ii) $y = 2f(x)$

(.....,) (1)

(iii) $y = f(3x)$

(.....,) (3)

The curve with equation $y = f(x)$ is transformed to give the curve with equation $y = f(x) - 4$

(b) Describe the transformation.

(1)

(Total for Question 24 is 4 marks)

TOTAL FOR PAPER IS 100 MARKS



BLANK PAGE

