

Write your name here

Surname

Other names

Pearson
Edexcel GCSE

Centre Number

--	--	--	--	--

Candidate Number

--	--	--	--

Mathematics A

Paper 2 (Calculator)

Higher Tier

Friday 6 November 2015 – Morning
Time: 1 hour 45 minutes

Paper Reference
1MA0/2H

You must have: Ruler graduated in centimetres and millimetres, protractor, pair of compasses, pen, HB pencil, eraser, calculator. Tracing paper may be used.

Total Marks



Instructions

- Use **black** ink or ball-point pen.
- **Fill in the boxes** at the top of this page with your name, centre number and candidate number.
- Answer **all** questions.
- Answer the questions in the spaces provided – *there may be more space than you need.*
- **Calculators may be used.**
- If your calculator does not have a π button, take the value of π to be 3.142 unless the question instructs otherwise.

Information

- The total mark for this paper is 100
- The marks for **each** question are shown in brackets – *use this as a guide as to how much time to spend on each question.*
- Questions labelled with an **asterisk** (*) are ones where the quality of your written communication will be assessed.

Advice

- Read each question carefully before you start to answer it.
- Keep an eye on the time.
- Try to answer every question.
- Check your answers if you have time at the end.

Turn over ►

P45840A

©2015 Pearson Education Ltd.

6/6/6/6/



PEARSON

GCSE Mathematics 1MA0

Formulae: Higher Tier

**You must not write on this formulae page.
Anything you write on this formulae page will gain NO credit.**

Volume of prism = area of cross section \times length

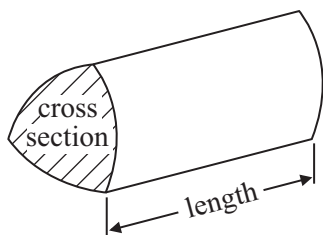

Area of trapezium = $\frac{1}{2} (a + b)h$

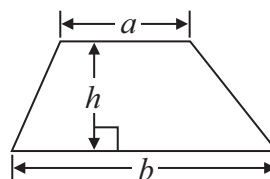

Volume of sphere = $\frac{4}{3} \pi r^3$

Surface area of sphere = $4\pi r^2$

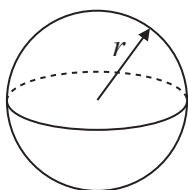

Volume of cone = $\frac{1}{3} \pi r^2 h$

Curved surface area of cone = $\pi r l$

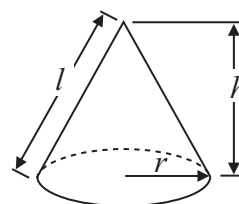

In any triangle ABC

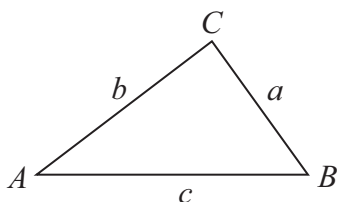

The Quadratic Equation

The solutions of $ax^2 + bx + c = 0$
where $a \neq 0$, are given by

$$x = \frac{-b \pm \sqrt{b^2 - 4ac}}{2a}$$

Sine Rule $\frac{a}{\sin A} = \frac{b}{\sin B} = \frac{c}{\sin C}$

Cosine Rule $a^2 = b^2 + c^2 - 2bc \cos A$

Area of triangle = $\frac{1}{2} ab \sin C$



Answer ALL questions.

Write your answers in the spaces provided.

You must write down all stages in your working.

1 Here are the lengths, in cm, of 15 tables.

28	51	42	23	63
38	44	29	32	37
61	35	39	41	25

Draw an ordered stem and leaf diagram for these lengths.

(Total for Question 1 is 3 marks)



2 A delivery driver records for each delivery the distance he drives and the time taken.

The scatter graph shows this information.

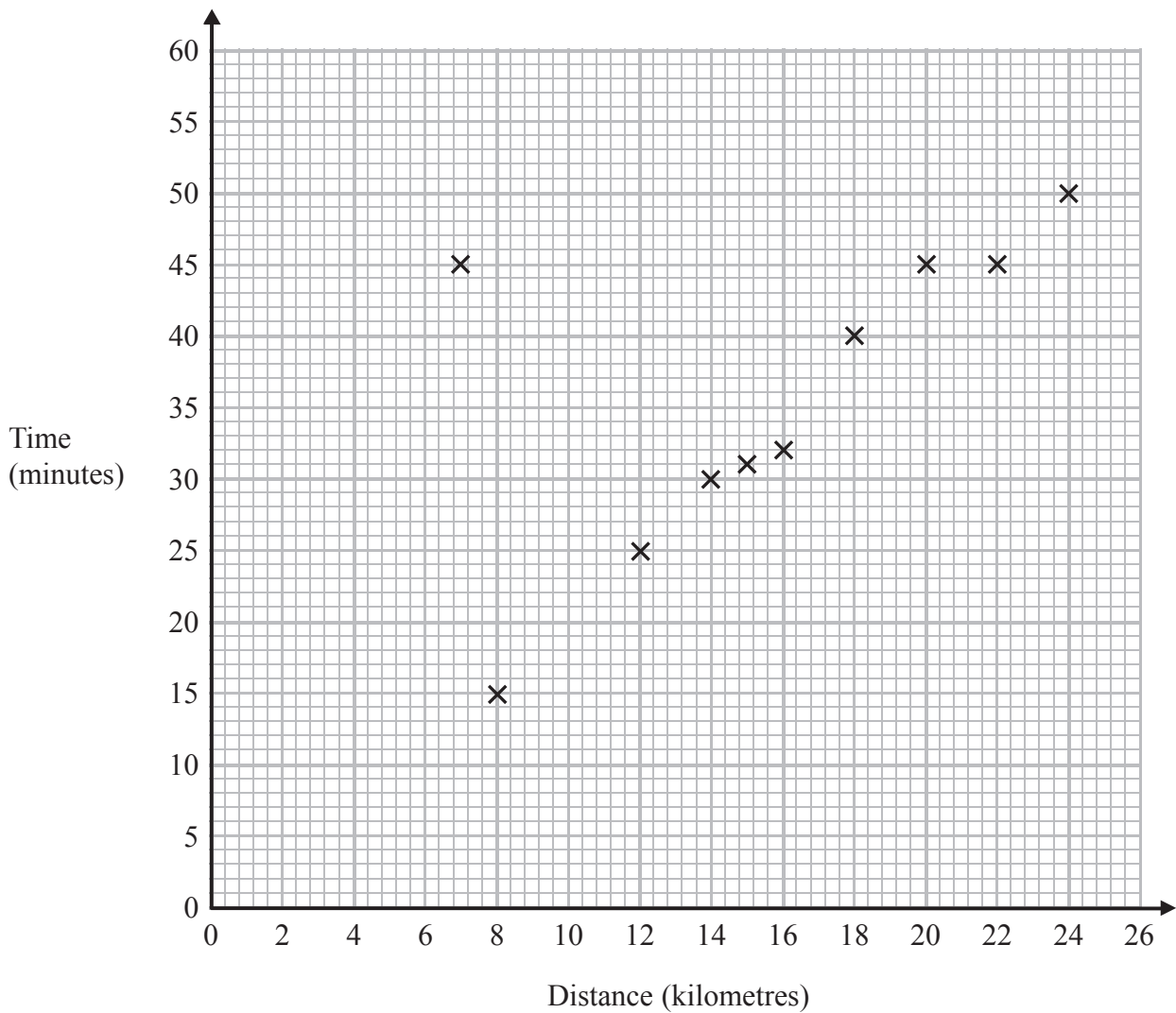

For another delivery he drives 22 kilometres and takes 50 minutes.

(a) Show this information on the scatter graph.

(1)

(b) What type of correlation does the scatter graph show?

.....
(1)



The driver has to drive a distance of 10 km for his next delivery.

(c) Estimate the time taken for this delivery.

..... minutes
(2)

During one of the deliveries, the driver was delayed by road works.

(d) Using the graph write down the time taken for this delivery.

..... minutes
(1)

(Total for Question 2 is 5 marks)

- 3** Ali is y years old.
Bhavara is twice as old as Ali.
Ceris is 3 years younger than Ali.
The total of their ages is 125 years.
Work out the age of each person.

Ali..... years

Bhavara..... years

Ceris..... years

(Total for Question 3 is 4 marks)



4 There are 18500 gallons of fuel in a fuel tank.

The fuel is pumped from the fuel tank into a plane at a rate of 1700 litres per minute.

1 gallon = 4.5 litres.

How many minutes will it take to empty the fuel tank completely?

Give your answer to the nearest minute.

..... minutes

(Total for Question 4 is 3 marks)



5 Celina and Zoe both sing in a band.

One evening the band plays for 80 minutes.
Celina sings for 65% of the 80 minutes.

Zoe sings for $\frac{5}{8}$ of the 80 minutes.

Celina sings for more minutes than Zoe sings.

Work out for how many more minutes.
You must show all your working.

..... minutes

(Total for Question 5 is 4 marks)

6 A rectangle has an area of 4 m².

Write this area in cm².

..... cm²

(Total for Question 6 is 2 marks)



*7 Here is part of a field.

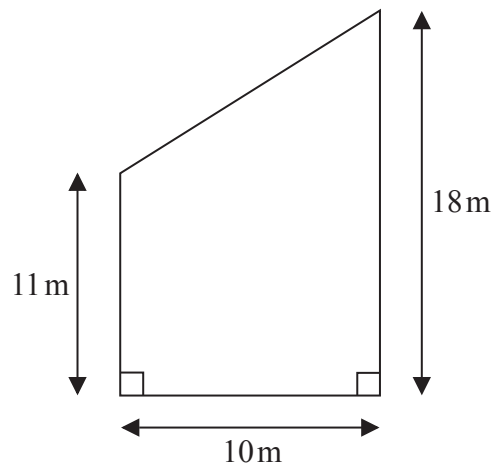

Diagram **NOT**
accurately drawn

This part of the field is in the shape of a trapezium.
A farmer wants to put a fence all the way around the edge of this part of the field.

The farmer has 50m of fence.

Does he have enough fence?
You must show all your working.

(Total for Question 7 is 5 marks)



*8 Toothpaste is sold in three different sizes of tube.

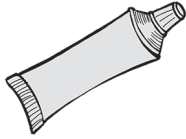

50ml

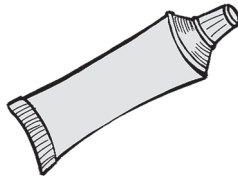

75ml

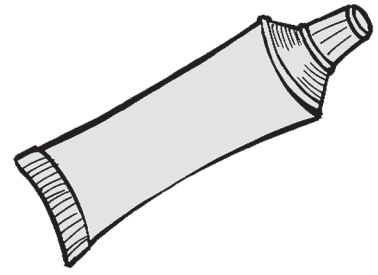

125ml

A 50ml tube costs £1.09

A 75ml tube costs £1.68

A 125ml tube costs £2.69

Which tube of toothpaste is the best value for money?

You must show all your working.

(Total for Question 8 is 4 marks)



9



Use ruler and compasses to **construct** the perpendicular bisector of the line segment *AB*.
You must show all your construction lines.

(Total for Question 9 is 2 marks)



10 A coach travels from Dronston to Luscoe.
The travel graph for this journey is shown below.

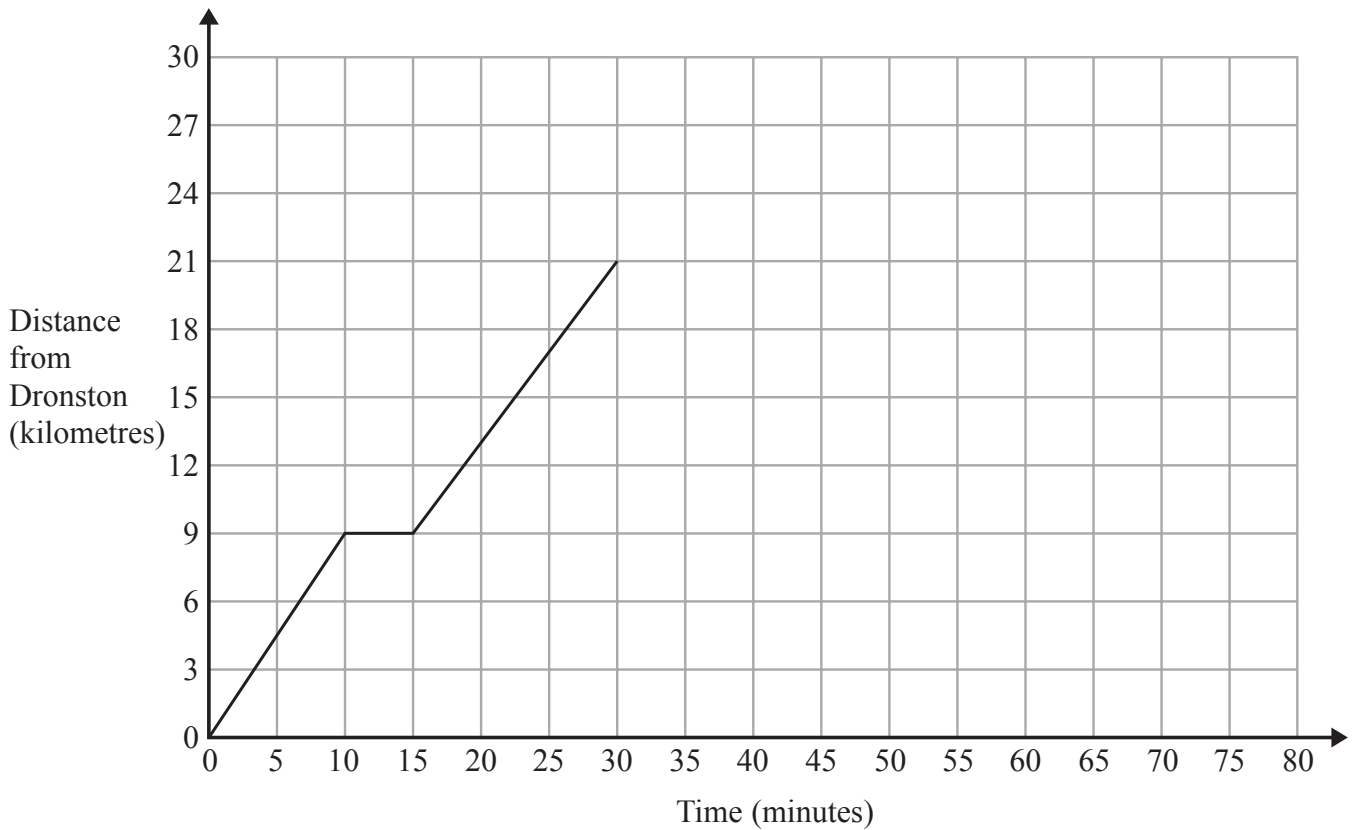

(a) Work out the average speed of the coach, in kilometres per hour, for the first 10 minutes of the journey.

..... km/h
(2)

The coach stops in Luscoe for 15 minutes.
The coach then returns to Dronston at a constant speed of 42 km/h.

(b) Show this information on the travel graph.

(3)

(Total for Question 10 is 5 marks)



11 (a) Solve $3x^2 = 147$

.....
(2)

(b) Work out the value of 2^{-3}

.....
(1)

(c) Simplify $(3x^2)^3$

.....
(2)

$$w = 4p - 16$$

(d) Make p the subject of this formula.

.....
(2)

(Total for Question 11 is 7 marks)



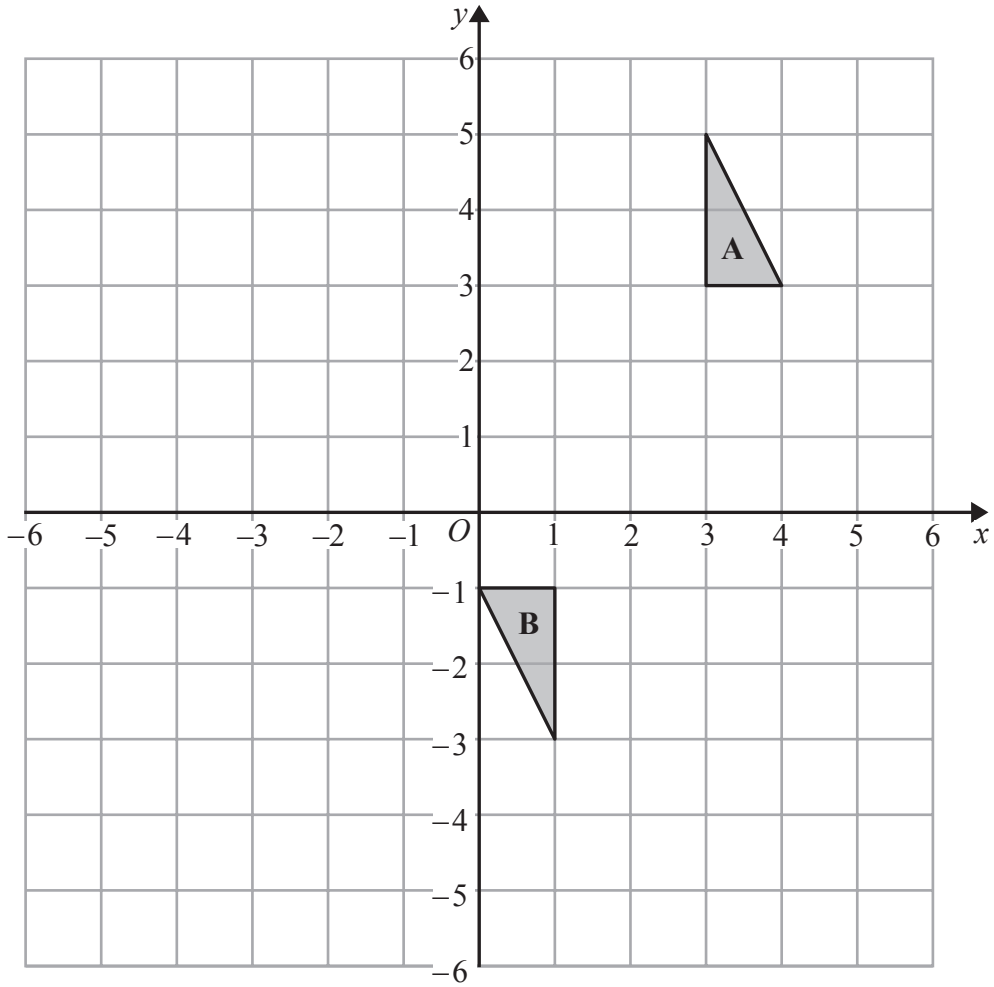

Describe fully the single transformation that maps triangle A onto triangle B.

.....

.....

.....

(Total for Question 12 is 3 marks)



13 (a) Given that x and y are integers such that

$$\begin{aligned}3 < x < 7 \\4 < y < 9 \\ \text{and } x + y = 13\end{aligned}$$

find all the possible values of x .

(2)

(b) On the grid below show, by shading, the region defined by the inequalities

$$y \geq -1 \quad y \leq 4 - x \quad y \leq 3x - 1$$

Mark this region with the letter R.

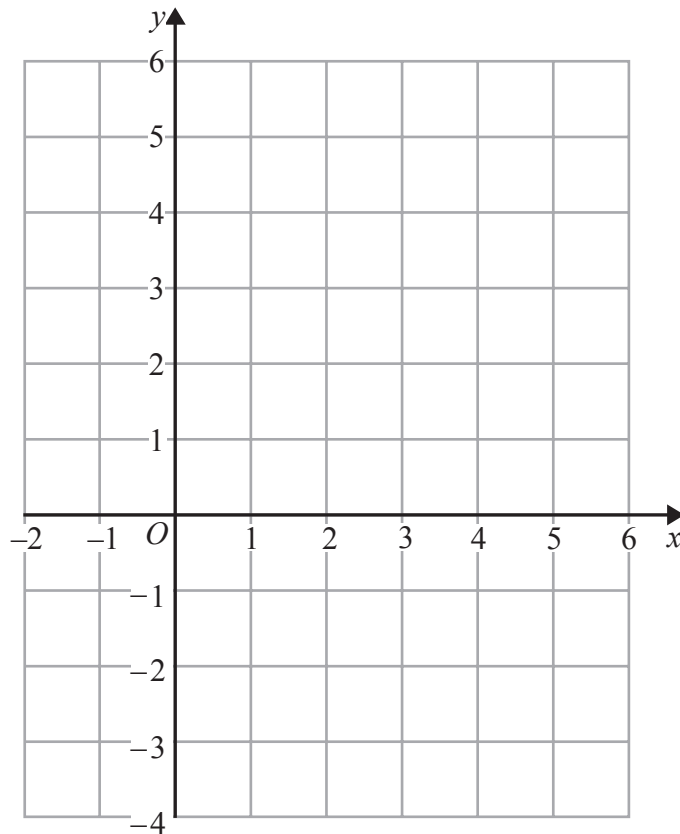

(4)

(Total for Question 13 is 6 marks)



14 Each year Wenford Hospital records how long patients wait to be treated in the Accident and Emergency department.

In 2015 patients waited 11% less time than in 2014
In 2015 the average time patients waited was 68 minutes.

- (a) Work out the average time patients waited in 2014
Give your answer to the nearest minute.

..... minutes
(3)

The hospital has a target to reduce the average time patients wait to be treated in the Accident and Emergency department to 60 minutes in 2016

- (b) Work out the percentage decrease from 68 minutes to 60 minutes.

..... %
(2)

(Total for Question 14 is 5 marks)



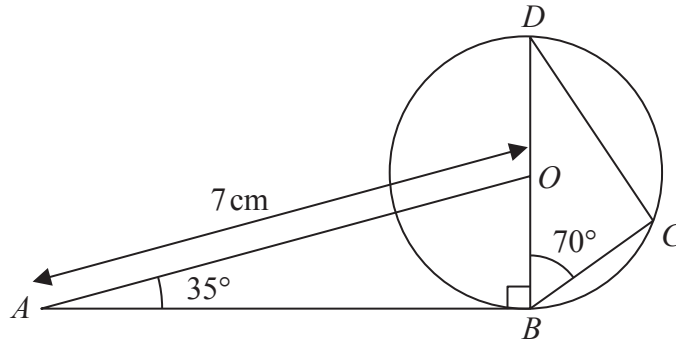

Diagram **NOT** accurately drawn

B , C and D are points on the circumference of a circle, centre O .
 BOD is a diameter of the circle.

$AO = 7 \text{ cm}$ Angle $ABO = 90^\circ$ Angle $OAB = 35^\circ$ Angle $DBC = 70^\circ$

*(a) Explain why angle BCD is 90°

(1)

(b) Calculate the length of BC .
 Give your answer correct to 3 significant figures.

..... cm

(4)

(Total for Question 15 is 5 marks)



16 (a) Write 640 000 000 in standard form.

.....
(1)

(b) Work out $(3 \times 10^7) \div (6 \times 10^4)$
Give your answer in standard form.

.....
(2)

(Total for Question 16 is 3 marks)

17 L_1 and L_2 are parallel lines.

The equation of L_1 is $y = 3x + 2$
 L_2 passes through the point (3, 4).

Find an equation for L_2 .

.....
(Total for Question 17 is 3 marks)



18 The box plot shows information about the number of countries competing in each Winter Olympic Games since 1948

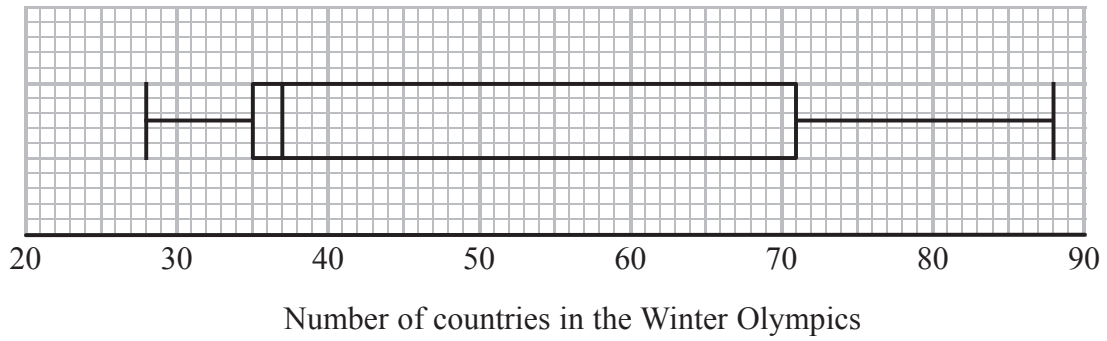

(a) Write down the median.

.....
(1)

(b) Work out the interquartile range.

.....
(2)

The table below shows information about the number of countries competing in each Summer Olympic Games since 1948

	Smallest	Lower quartile	Median	Upper quartile	Largest
Number of countries	59	83	121	199	204

*(c) Compare the two distributions.

.....
.....
.....
.....
.....
(2)

(Total for Question 18 is 5 marks)



19 The value of p is 4.3
The value of q is 0.4

Both p and q are given correct to the nearest 0.1

(a) Write down the lower bound for p .

$$r = p + \frac{1}{q}$$

.....
(1)

(b) Work out the upper bound for r .
You must show all your working.

.....
(3)

(Total for Question 19 is 4 marks)



20 Here are two watch faces, **A** and **B**.

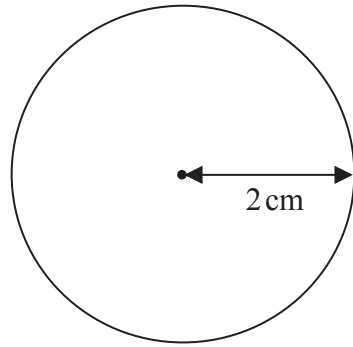

face **A**

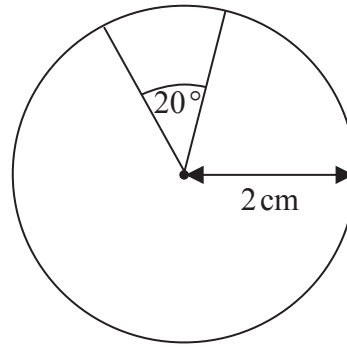

face **B**

Diagram **NOT**
accurately drawn

Both watch faces are circular with radius 2 cm.

The materials used to make both watch faces have the same thickness.

A is made entirely of plastic.

B has a 20° sector of metal and a 340° sector of plastic.

The ratio of the cost per cm^2 of the metal to the cost per cm^2 of the plastic is 3:2

Work out the ratio of the cost of the materials for **A** to the cost of the materials for **B**.

Give your answer in its simplest form.

You must show all your working.

(Total for Question 20 is 4 marks)



21 148 students went to Brighton.

Each student went to the Aquarium or the Brighton Wheel or the Royal Pavilion.

The table gives information about these students.

	Aquarium	Brighton Wheel	Royal Pavilion
Male	16	15	22
Female	36	35	24

The teacher takes a sample of 40 of these students.

The sample is stratified by gender and by place visited.

Work out the number of students in the sample who are female and went to the Brighton Wheel.

.....
(Total for Question 21 is 2 marks)

22 Alison is using the quadratic formula to solve a quadratic equation.

She substitutes values into the formula and correctly gets

$$x = \frac{-7 \pm \sqrt{49 - 32}}{4}$$

Work out the quadratic equation that Alison is solving.

Give your answer in the form $ax^2 + bx + c = 0$, where a , b and c are integers.

.....
(Total for Question 22 is 3 marks)



23 Here is the graph of $y = \sin x^\circ$ for $-180 \leq x \leq 180$

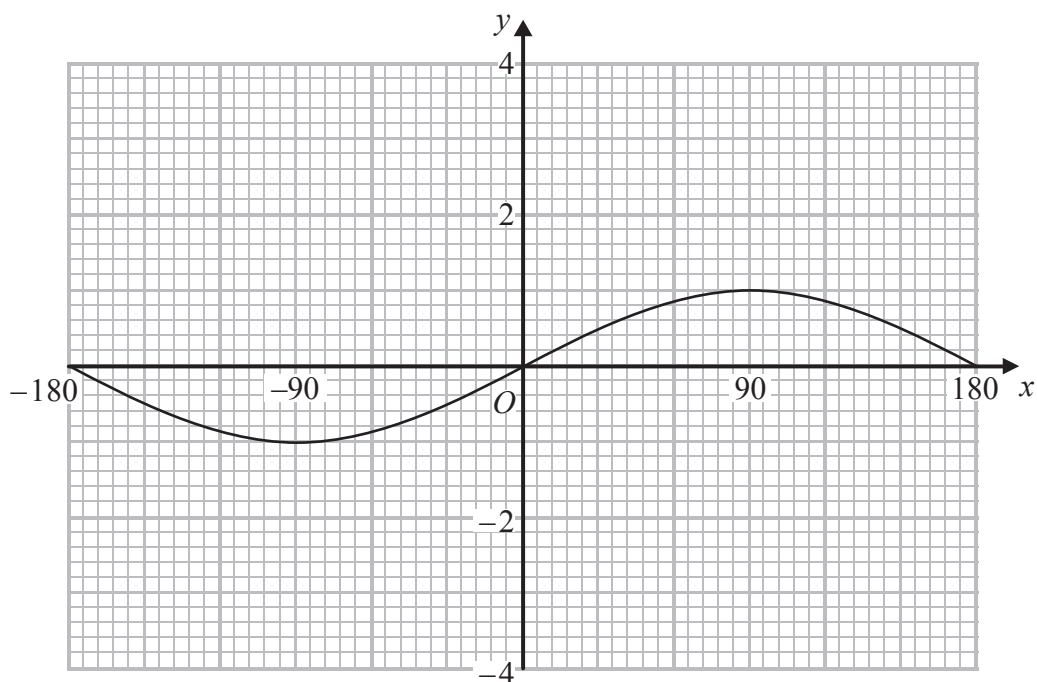

(a) On the grid above, sketch the graph of $y = \sin x^\circ + 2$ for $-180 \leq x \leq 180$

(2)

Here is the graph of $y = \cos x^\circ$ for $-180 \leq x \leq 180$

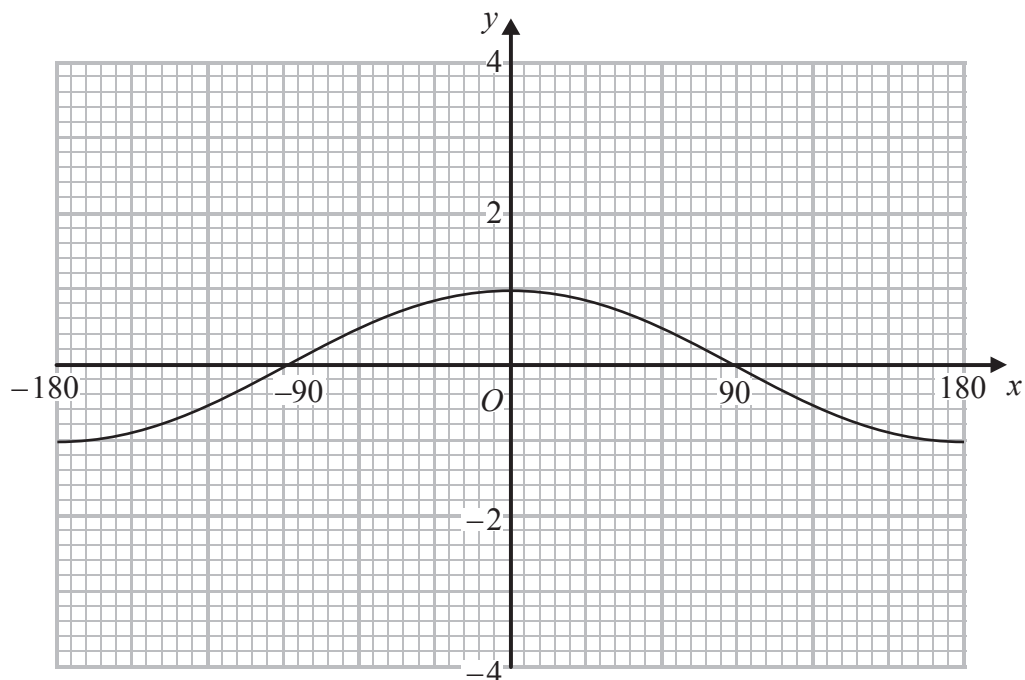

(b) On the grid above, sketch the graph of $y = -2 \cos x^\circ$ for $-180 \leq x \leq 180$

(2)

(Total for Question 23 is 4 marks)



24 ABC is a triangle.

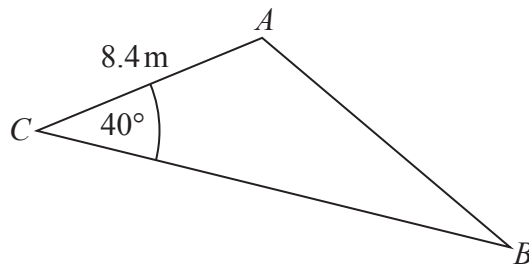

Diagram **NOT**
accurately drawn

$AC = 8.4\text{ m}$
Angle $ACB = 40^\circ$

The area of the triangle = 100 m^2 .

Work out the length of AB .
Give your answer correct to 3 significant figures.
You must show all your working.

..... m

(Total for Question 24 is 5 marks)



25 Nomusa has 30 sweets.

She has

18 fruit sweets

7 aniseed sweets

5 mint sweets

Nomusa is going to take at random two sweets.

Work out the probability that the two sweets will **not** be the same type of sweet.

You must show all your working.

.....
(Total for Question 25 is 4 marks)

TOTAL FOR PAPER IS 100 MARKS

