

Write your name here

Surname

Other names

Centre Number

Candidate Number

Edexcel GCSE

Mathematics B

**Unit 2: Number, Algebra, Geometry 1
(Non-Calculator)**

Foundation Tier

Tuesday 1 March 2011 – Afternoon

Time: 1 hour 15 minutes

Paper Reference

5MB2F/01

You must have:

Ruler, graduated in centimetres and millimetres, protractor, compasses, pen, HB pencil, eraser. Tracing paper may be used.

Total Marks

Instructions

- Use **black** ink or ball-point pen.
- **Fill in the boxes** at the top of this page with your name, centre number and candidate number.
- Answer **all** questions.
- Answer the questions in the spaces provided – *there may be more space than you need.*
- **Calculators must not be used.**



Information

- The total mark for this paper is 60.
- The marks for **each** question are shown in brackets – *use this as a guide as to how much time to spend on each question.*
- Questions labelled with an **asterisk** (*) are ones where the quality of your written communication will be assessed – *you should take particular care on these questions with your spelling, punctuation and grammar, as well as the clarity of expression.*

Advice

- Read each question carefully before you start to answer it.
- Keep an eye on the time.
- Try to answer every question.
- Check your answers if you have time at the end.

Turn over ►

P38976A

©2011 Edexcel Limited.

6/6/6



edexcel 
advancing learning, changing lives

GCSE Mathematics 2MB01

Formulae: Foundation Tier

**You must not write on this formulae page.
Anything you write on this formulae page will gain NO credit.**

Area of trapezium = $\frac{1}{2}(a + b)h$

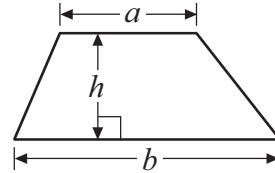

Volume of prism = area of cross section \times length

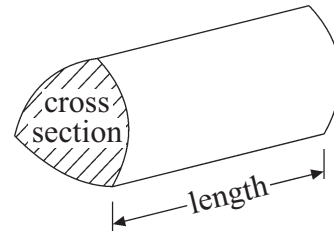

Answer ALL questions.

Write your answers in the spaces provided.

You must write down all stages in your working.

1 (a) On the grid, draw a kite.

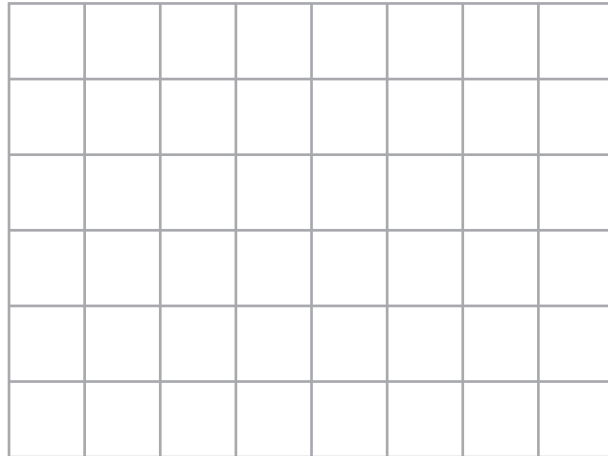

(1)

(b) Here is a quadrilateral.



Write down the special name of this quadrilateral.

.....
(1)

(Total for Question 1 is 2 marks)



2 (a) Work out $90 \div 10$

.....
(1)

(b) Write these numbers in order of size.
Start with the smallest number.

2.8 4.71 0.6 13.4

.....
(1)

(c) Write $\frac{7}{10}$ as a decimal.

.....
(1)

(Total for Question 2 is 3 marks)

3 Here is a regular pentagon.

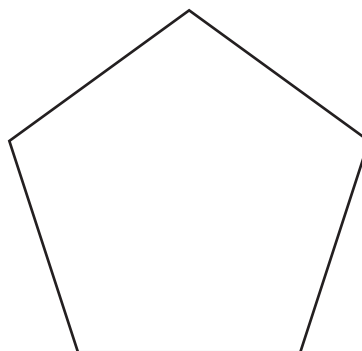

(a) What is the order of rotational symmetry of this pentagon?

.....
(1)

(b) Draw a line of symmetry on this pentagon.

(1)

(Total for Question 3 is 2 marks)



4 (i) What type of angle is this?

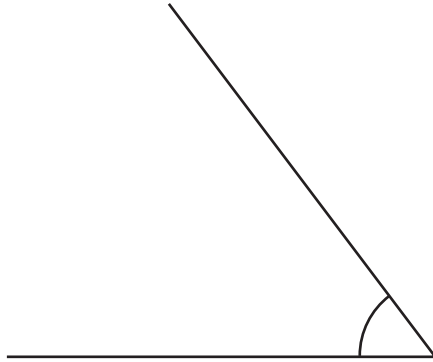

.....

(ii) Measure the size of the angle.

..... °

(Total for Question 4 is 2 marks)

5

Diagram **NOT**
accurately drawn

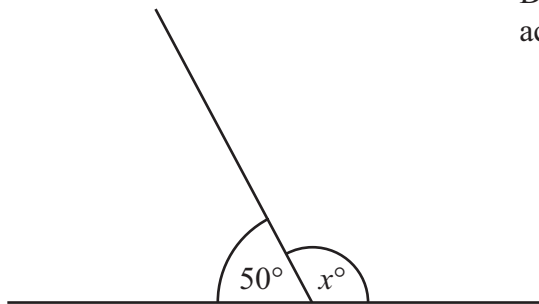

(i) Work out the value of x .

$x =$

(ii) Give a reason for your answer.

.....
.....

(Total for Question 5 is 2 marks)



6 (a) Simplify $c + c + c$

.....
(1)

(b) Simplify $4x + 5y - 2x + y$

.....
(2)

(Total for Question 6 is 3 marks)

7 Here are some patterns made from dots.



Pattern number 1



Pattern number 2



Pattern number 3

(a) Draw Pattern number 4 in the space below.

(1)

(b) How many dots are needed for Pattern number 15?

.....
(2)

(Total for Question 7 is 3 marks)



***8** Yusuf is planning a disco party at his Youth Club.
Here are his costs.

Mobile Disco	£230
Hire of room	£150
Other costs	£30
Food	£12 per person

Yusuf charges £16 per ticket.
He sells 100 tickets.

Is there enough money from the ticket sales for Yusuf to pay all his costs?
You must show your working.

(Total for Question 8 is 4 marks)



- 9 The table shows the highest temperature and the lowest temperature in London and in Oslo on the same day.

	Highest	Lowest
London	8°C	-7°C
Oslo	-4°C	-9°C

- (a) Work out the difference between the **lowest** temperature in London and the **lowest** temperature in Oslo.

..... °C
(1)

- (b) Work out the difference between the **highest** temperature in London and the **lowest** temperature in London.

..... °C
(1)

(Total for Question 9 is 2 marks)

- 10 (a) Work out $\frac{1}{2} \times \frac{1}{5}$

.....
(1)

- (b) Work out $\frac{1}{2} + \frac{3}{8}$

Give your answer in its simplest form.

.....
(2)

(Total for Question 10 is 3 marks)



11 Here is a diagram of a cuboid.

Diagram **NOT**
accurately drawn

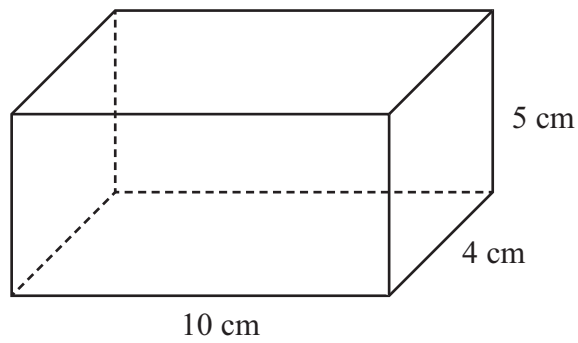

(a) Write down the number of edges of the cuboid.

.....
(1)

(b) Calculate the volume of the cuboid.

.....
(3)

(Total for Question 11 is 4 marks)



*12 Barbara goes on holiday to Prague. The currency in Prague is the Koruna (KC).

This graph can be used to convert between £ (pounds) and KC (Koruna).
The exchange rate is £1 = 30 KC.

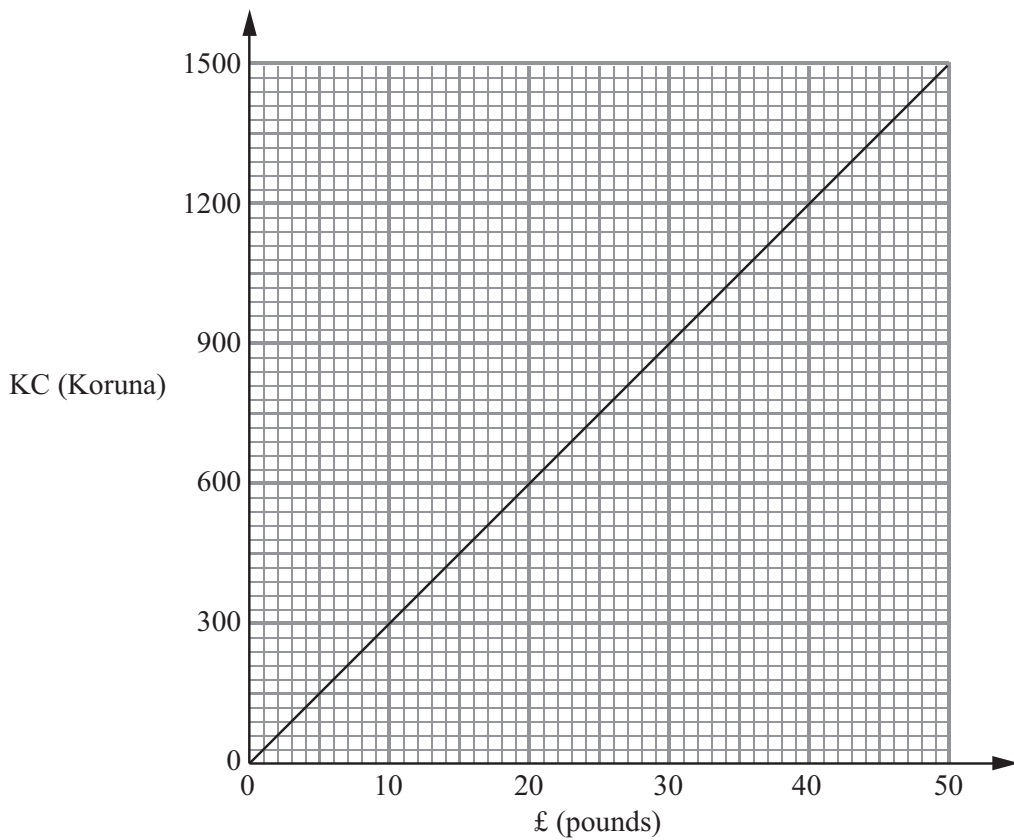

Barbara bought some things in London.
She saw the same things on sale in Prague.

The table shows the cost in £ (pounds) and the cost in KC (Koruna).

Item	Cost in London £ (pounds)	Cost in Prague KC (Koruna)
Headphones	£15	450 KC
Suitcase	£34	750 KC
Music player	£26	810 KC



Barbara thinks the total cost of these things was more in London than in Prague.

Is she correct?

Give a reason for your answer.

You must show all your working.

(Total for Question 12 is 5 marks)



*13 Comp Parts and Z Parts both sell memory sticks.

Comp Parts
Memory sticks £4 each

1 free stick for every 10 sticks bought

Z Parts
Memory sticks

£35 for a box of 10 sticks

There are 150 students in Year 10 in a school.
A teacher needs to buy a memory stick for each student.

At which of the shops should he buy the memory sticks?
You must show all your working.

(Total for Question 13 is 5 marks)



14 On the grid, draw the graph of $y = 2x + 3$ for values of x from $x = -3$ to $x = 1$

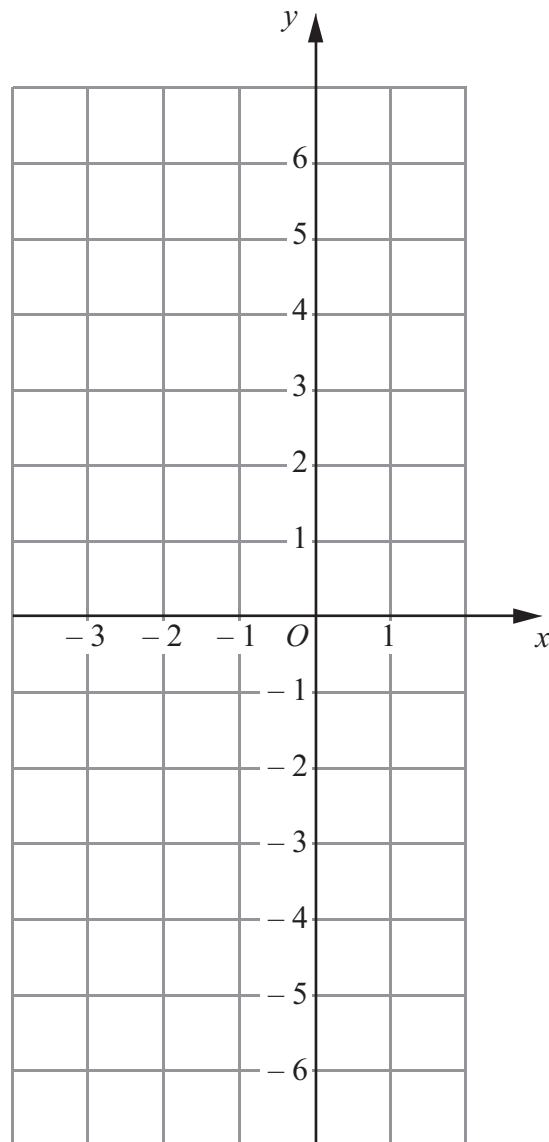

(Total for Question 14 is 3 marks)



15 Work out 342×24

.....
(Total for Question 15 is 3 marks)



16 Here are the first four terms of an arithmetic sequence.

5 9 13 17

(a) What is the next term of this sequence?

.....
(1)

(b) Write down an expression, in terms of n , for the n th term of the sequence.

.....
(2)

(Total for Question 16 is 3 marks)

17 Ali, Ben and Candice share £300 in the ratio 2 : 3 : 5

How much money does Candice get?

£

(Total for Question 17 is 2 marks)



18 Veena bought some food for a barbecue.
She is going to make some hot dogs.
She needs a bread roll and a sausage for each hot dog.

There are 40 bread rolls in a pack.
There are 24 sausages in a pack.

Veena bought exactly the same number of bread rolls and sausages.

(i) How many packs of bread rolls and packs of sausages did she buy?

..... packs of bread rolls

..... packs of sausages.

(ii) How many hot dogs can she make?

..... hot dogs

(Total for Question 18 is 5 marks)



19 Here is a solid cuboid.

Diagram **NOT**
accurately drawn

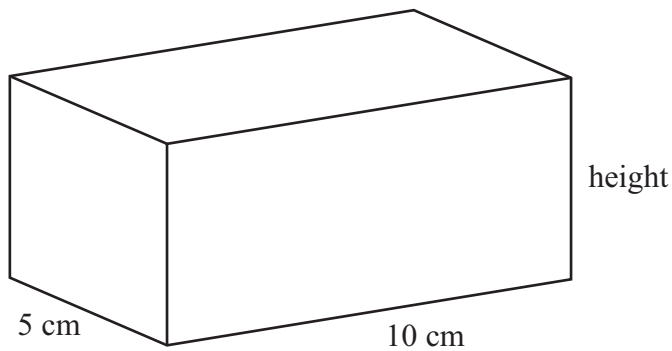

The cuboid has a width of 5 cm and a length of 10 cm.
The cuboid has a total surface area of 280 cm^2 .

Work out the height of the cuboid.

..... cm

(Total for Question 19 is 4 marks)

TOTAL FOR PAPER IS 60 MARKS



BLANK PAGE



BLANK PAGE



BLANK PAGE

