

Write your name here

Surname

Other names

**Pearson**  
**Edexcel GCSE**

Centre Number

--	--	--	--	--	--

Candidate Number

--	--	--	--	--

# Mathematics B

**Unit 2: Number, Algebra, Geometry 1**  
**(Non-Calculator)**

**Higher Tier**

Thursday 9 June 2016 – Morning

**Time: 1 hour 15 minutes**

Paper Reference

**5MB2H/01**

**You must have:** Ruler graduated in centimetres and millimetres, protractor, pair of compasses, pen, HB pencil, eraser. Tracing paper may be used.

Total Marks

## Instructions

- Use **black** ink or ball-point pen.
- **Fill in the boxes** at the top of this page with your name, centre number and candidate number.
- Answer **all** questions.
- Answer the questions in the spaces provided – *there may be more space than you need.*
- **Calculators must not be used.**



## Information

- The total mark for this paper is 60
- The marks for **each** question are shown in brackets – *use this as a guide as to how much time to spend on each question.*
- Questions labelled with an **asterisk** (\*) are ones where the quality of your written communication will be assessed.

## Advice

- Read each question carefully before you start to answer it.
- Keep an eye on the time.
- Try to answer every question.
- Check your answers if you have time at the end.

Turn over ►

P46554A

©2016 Pearson Education Ltd.

6/6/6/



**PEARSON**

## GCSE Mathematics 2MB01

Formulae: Higher Tier

**You must not write on this formulae page.  
Anything you write on this formulae page will gain NO credit.**

**Volume of prism** = area of cross section  $\times$  length

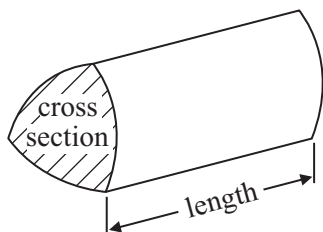

**Area of trapezium** =  $\frac{1}{2} (a + b)h$

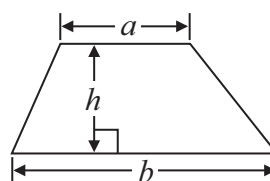

**Volume of sphere** =  $\frac{4}{3} \pi r^3$

**Surface area of sphere** =  $4\pi r^2$

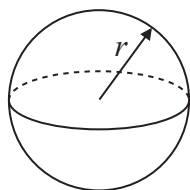

**Volume of cone** =  $\frac{1}{3} \pi r^2 h$

**Curved surface area of cone** =  $\pi r l$

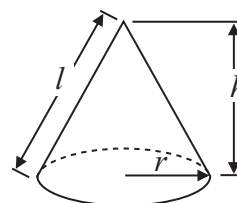

**In any triangle ABC**

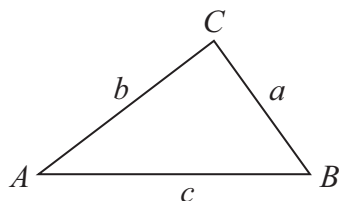

**The Quadratic Equation**

The solutions of  $ax^2 + bx + c = 0$  where  $a \neq 0$ , are given by

$$x = \frac{-b \pm \sqrt{b^2 - 4ac}}{2a}$$

**Sine Rule**  $\frac{a}{\sin A} = \frac{b}{\sin B} = \frac{c}{\sin C}$

**Cosine Rule**  $a^2 = b^2 + c^2 - 2bc \cos A$

**Area of triangle** =  $\frac{1}{2} ab \sin C$

DO NOT WRITE IN THIS AREA

DO NOT WRITE IN THIS AREA

DO NOT WRITE IN THIS AREA



**Answer ALL questions.**

**Write your answers in the spaces provided.**

**You must write down all stages in your working.**

**You must NOT use a calculator.**

- 1** Sally has £520  
Katie has £360

Sally and Katie are each going to give 15% of their money to charity.

Work out the total amount of money they give to charity.

£.....

**(Total for Question 1 is 3 marks)**

- 2**  $p = n^3 - 5$   
 $n = 2$

Work out the value of  $p$ .

.....  
**(Total for Question 2 is 2 marks)**



- 3 Stephanie uses her grandmother's recipe to make apple amber. Here is the list of ingredients to make 8 portions.

<p><b>Apple amber</b> (makes 8 portions)</p> <p><math>2\frac{1}{2}</math> pounds apples</p> <p>10 ounces sugar</p> <p>4 eggs</p>
--

Stephanie wants to make 12 portions of apple amber.

- (a) Work out how much sugar she needs.

..... ounces  
(2)

Stephanie has 2kg of apples.

- (b) Show that she has enough apples to make 12 portions of apple amber.  
You must show your working.

(3)

**(Total for Question 3 is 5 marks)**

DO NOT WRITE IN THIS AREA

DO NOT WRITE IN THIS AREA

DO NOT WRITE IN THIS AREA

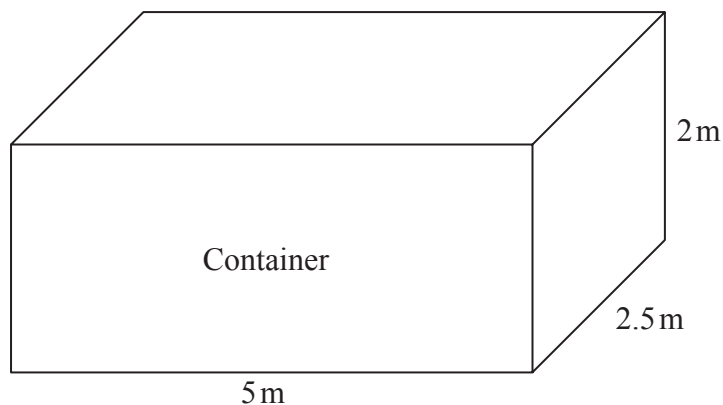
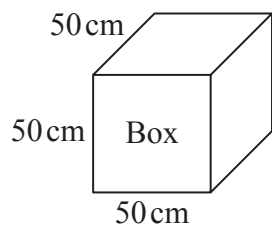

\*4

Diagram **NOT**  
accurately drawn

Chao transports microwave ovens from China to the UK.

He puts each microwave oven in a box.  
Each box is a cube of side 50 cm.

He then puts each box in a container.  
Each container is a cuboid of size 5 m by 2.5 m by 2 m.

Chao has 500 boxes.  
He has 3 containers.

Will the 500 boxes fit into these 3 containers?

(Total for Question 4 is 4 marks)



5

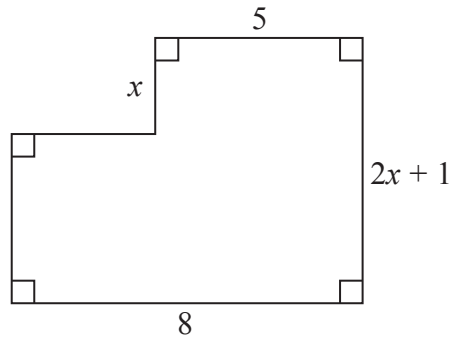

Diagram **NOT**  
accurately drawn

Here is a shape.  
All the measurements are in metres.

The area of the shape is  $A \text{ m}^2$ .

Find a formula for  $A$  in terms of  $x$ .

(Total for Question 5 is 3 marks)

DO NOT WRITE IN THIS AREA

DO NOT WRITE IN THIS AREA

DO NOT WRITE IN THIS AREA

6



- 6 On the grid, draw the graph of  $y = 3x - 2$  for values of  $x$  from  $-2$  to  $3$

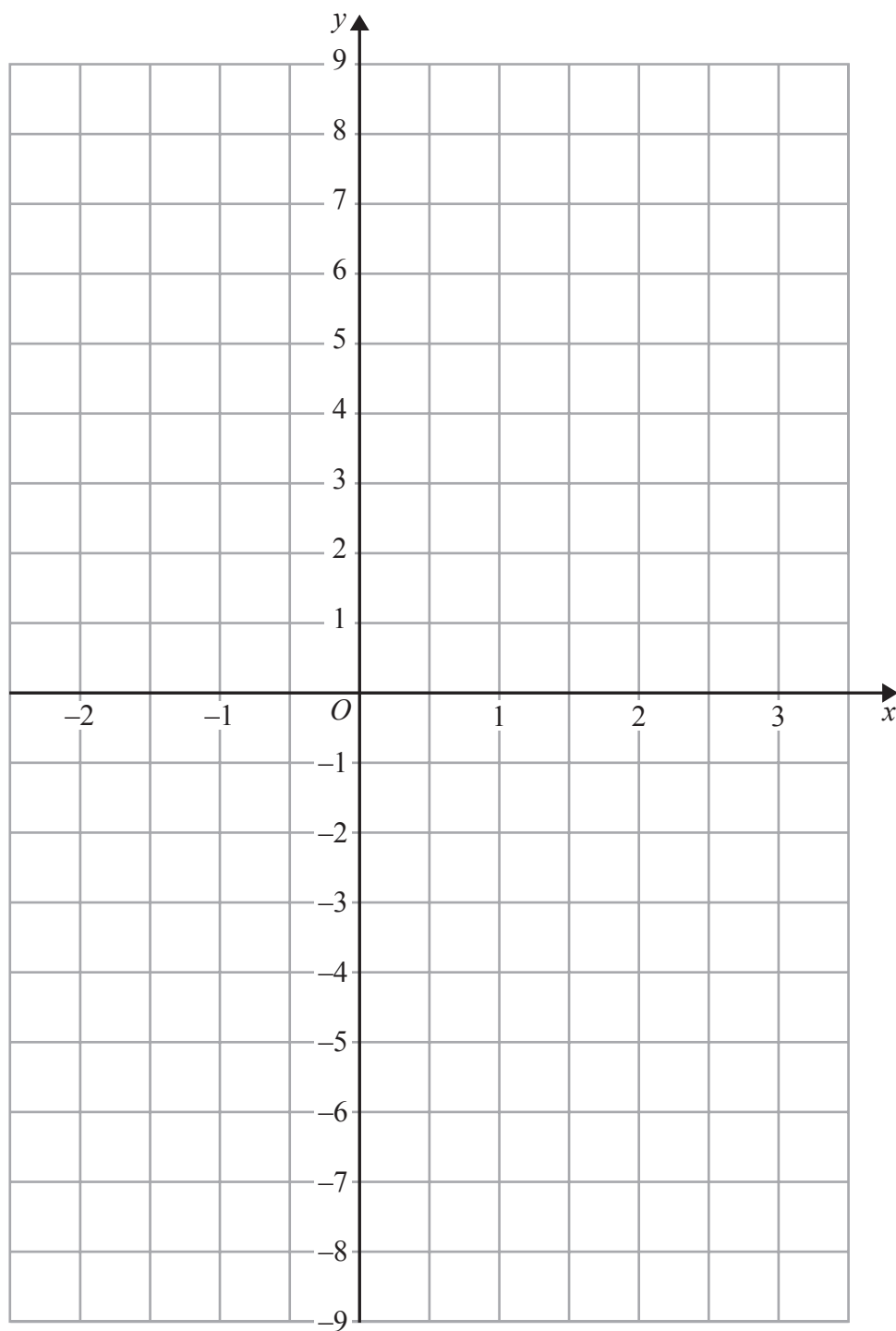

(Total for Question 6 is 3 marks)



7 Shelley sells books.

On Saturday she is going to give a free book mark and a free dust cover with each book she sells.

All the books are the same size.

Shelley needs to buy the book marks and the dust covers.

Book marks come in boxes.

Each box contains 24 book marks.

Dust covers come in packs.

Each pack contains 36 dust covers.

Shelley wants to have enough book marks and dust covers for 250 books.

She buys exactly the same number of book marks and dust covers.

Work out the number of boxes of book marks and the number of packs of dust covers she buys.

You must show all your working.

..... boxes of book marks

..... packs of dust covers

**(Total for Question 7 is 4 marks)**

DO NOT WRITE IN THIS AREA

DO NOT WRITE IN THIS AREA

DO NOT WRITE IN THIS AREA



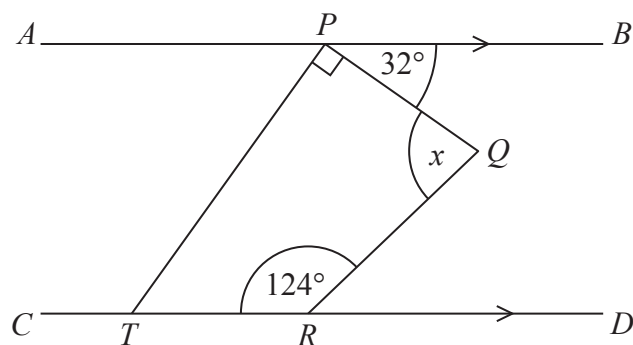

8

Diagram **NOT**  
accurately drawn

$APB$  is parallel to  $CTRD$ .  
 $PQRT$  is a quadrilateral.

Work out the size of the angle marked  $x$ .  
 You must show your working.

.....  
 (Total for Question 8 is 4 marks)



9

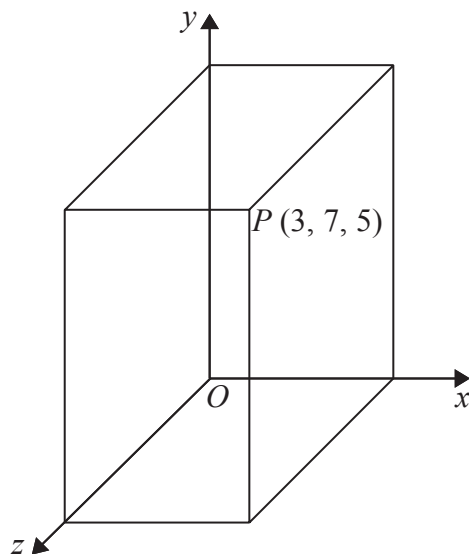

Diagram **NOT**  
accurately drawn

The diagram shows a cuboid drawn on a 3-D coordinate grid.  
All measurements are in cm.

$P$  is a vertex of the cuboid.  
The coordinates of  $P$  are  $(3, 7, 5)$ .

Work out the surface area of the cuboid.

..... cm<sup>2</sup>

**(Total for Question 9 is 3 marks)**

DO NOT WRITE IN THIS AREA

DO NOT WRITE IN THIS AREA

DO NOT WRITE IN THIS AREA



10 (a) Simplify  $a^4 \times a^3$

.....  
(1)

(b) Simplify  $(b^2)^7$

.....  
(1)

(c) Write down the value of  $3^0$

.....  
(1)

(d) Write down the value of  $4^{-1}$

.....  
(1)

**(Total for Question 10 is 4 marks)**

11 (a) Write 0.00059 in standard form.

.....  
(1)

(b) Write  $3.8 \times 10^5$  as an ordinary number.

.....  
(1)

**(Total for Question 11 is 2 marks)**

DO NOT WRITE IN THIS AREA

DO NOT WRITE IN THIS AREA

DO NOT WRITE IN THIS AREA



12 (a) Factorise  $2ax - 2ay + bx - by$

.....  
(2)

(b) Expand and simplify  $(n + 2)^2 + (n - 3)^2$

.....  
(3)

(Total for Question 12 is 5 marks)

DO NOT WRITE IN THIS AREA

DO NOT WRITE IN THIS AREA

DO NOT WRITE IN THIS AREA



13 Work out  $8\frac{1}{3} \times 1\frac{2}{5}$

Give your answer as a mixed number in its simplest form.

DO NOT WRITE IN THIS AREA

DO NOT WRITE IN THIS AREA

DO NOT WRITE IN THIS AREA

(Total for Question 13 is 3 marks)

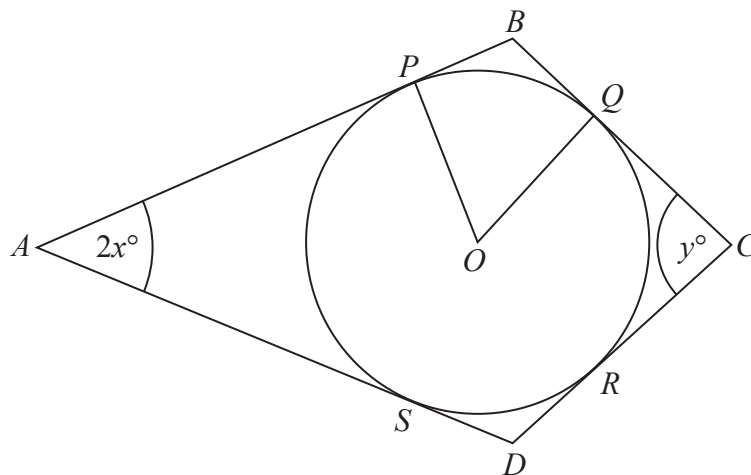

\*14

Diagram NOT  
accurately drawn

$P$ ,  $Q$ ,  $R$  and  $S$  are points on the circumference of a circle, centre  $O$ .  
 $APB$ ,  $BQC$ ,  $CRD$  and  $DSA$  are tangents to the circle.  
 $ABCD$  is a kite.

Angle  $PAS = 2x^\circ$

Angle  $QCR = y^\circ$

Find an expression in terms of  $x$  and  $y$  for the size, in degrees, of the angle  $POQ$ .

Give your expression in its simplest form.

Give reasons for your answer.

(Total for Question 14 is 5 marks)

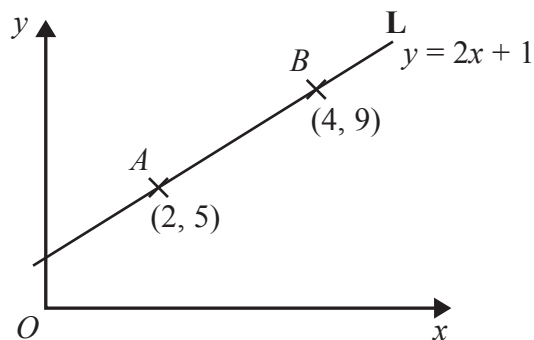

15

Diagram **NOT**  
accurately drawn

The point  $A$  has coordinates  $(2, 5)$ .  
The point  $B$  has coordinates  $(4, 9)$ .

The line  $L$  passes through the points  $A$  and  $B$ .  
The equation of line  $L$  is  $y = 2x + 1$

$M$  is the midpoint of the line segment  $AB$ .

Find an equation of the line that is perpendicular to line  $L$  and passes through  $M$ .

(Total for Question 15 is 4 marks)



16  $\frac{\sqrt{3}}{5} + \frac{2}{\sqrt{3}} = a\sqrt{3}$ , where  $a$  is a fraction.

Find the value of  $a$ .

.....  
(Total for Question 16 is 3 marks)

17 Simplify fully  $\frac{2x^2 + 5x - 3}{x^2 - 9}$

.....  
(Total for Question 17 is 3 marks)

TOTAL FOR PAPER IS 60 MARKS

DO NOT WRITE IN THIS AREA

DO NOT WRITE IN THIS AREA

DO NOT WRITE IN THIS AREA

