

Surname	Centre Number	Candidate Number
Other Names		0



New GCSE

4473/02

**ADDITIONAL SCIENCE
HIGHER TIER
PHYSICS 2**

P.M. THURSDAY, 17 January 2013

1 hour

For Examiner's use only		
Question	Maximum Mark	Mark Awarded
1.	8	
2.	12	
3.	6	
4.	7	
5.	15	
6.	8	
7.	4	
Total	60	

4473
020001

ADDITIONAL MATERIALS

In addition to this paper you may require a calculator.

INSTRUCTIONS TO CANDIDATES

Use black ink or black ball-point pen. Do not use a gel pen. Do not use correction fluid.

Write your name, centre number and candidate number in the spaces at the top of this page.

Answer **all** questions.

Write your answers in the spaces provided in this booklet. If you run out of space, use the continuation page at the back of the booklet, taking care to number the question(s) correctly.

INFORMATION FOR CANDIDATES

The number of marks is given in brackets at the end of each question or part-question.

You are reminded of the necessity for good English and orderly presentation in your answers.

A list of equations is printed on page 2. In calculations you should show all your working.

You are reminded that assessment will take into account the quality of written communication (QWC) used in your answers to questions **3** and **6(b)**.



Equations

power = voltage \times current	$P = VI$
resistance = $\frac{\text{voltage}}{\text{current}}$	$R = \frac{V}{I}$
power = current ² \times resistance	$P = I^2R$
speed = $\frac{\text{distance}}{\text{time}}$	
acceleration [or deceleration] = $\frac{\text{change in velocity}}{\text{time}}$	$a = \frac{\Delta v}{t}$
acceleration = gradient of a velocity-time graph	
distance travelled = area under a velocity-time graph	
momentum = mass \times velocity	$p = mv$
resultant force = mass \times acceleration	$F = ma$
force = $\frac{\text{change in momentum}}{\text{time}}$	$F = \frac{\Delta p}{t}$
work = force \times distance	$W = Fd$
kinetic energy = $\frac{\text{mass} \times \text{speed}^2}{2}$	$\text{KE} = \frac{1}{2} mv^2$
change in potential energy = mass \times gravitational field strength \times change in height	$\text{PE} = mgh$

SI multipliers

Prefix	Multiplier
p	10^{-12}
n	10^{-9}
μ	10^{-6}
m	10^{-3}

Prefix	Multiplier
k	10^3
M	10^6
G	10^9
T	10^{12}



BLANK PAGE

**PLEASE DO NOT WRITE
ON THIS PAGE**

4473
02/00/03



Answer **all** questions in the spaces provided.

1. The diagram shows a circuit used to investigate currents in a parallel circuit when the voltage is varied. A lamp **L** and a wire **W** are connected in parallel with a variable voltage supply. The circuit has 3 ammeters A_1 , A_2 and A_3 as shown.

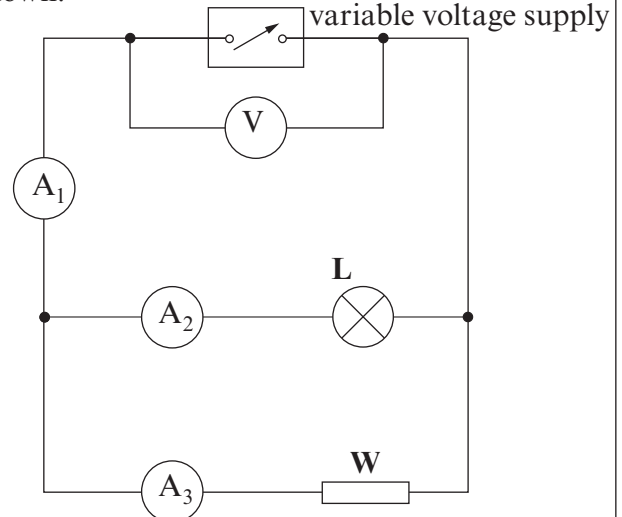

The currents through the lamp, **L**, and the wire, **W**, depend on the voltage applied to them in the way shown on the graph below.

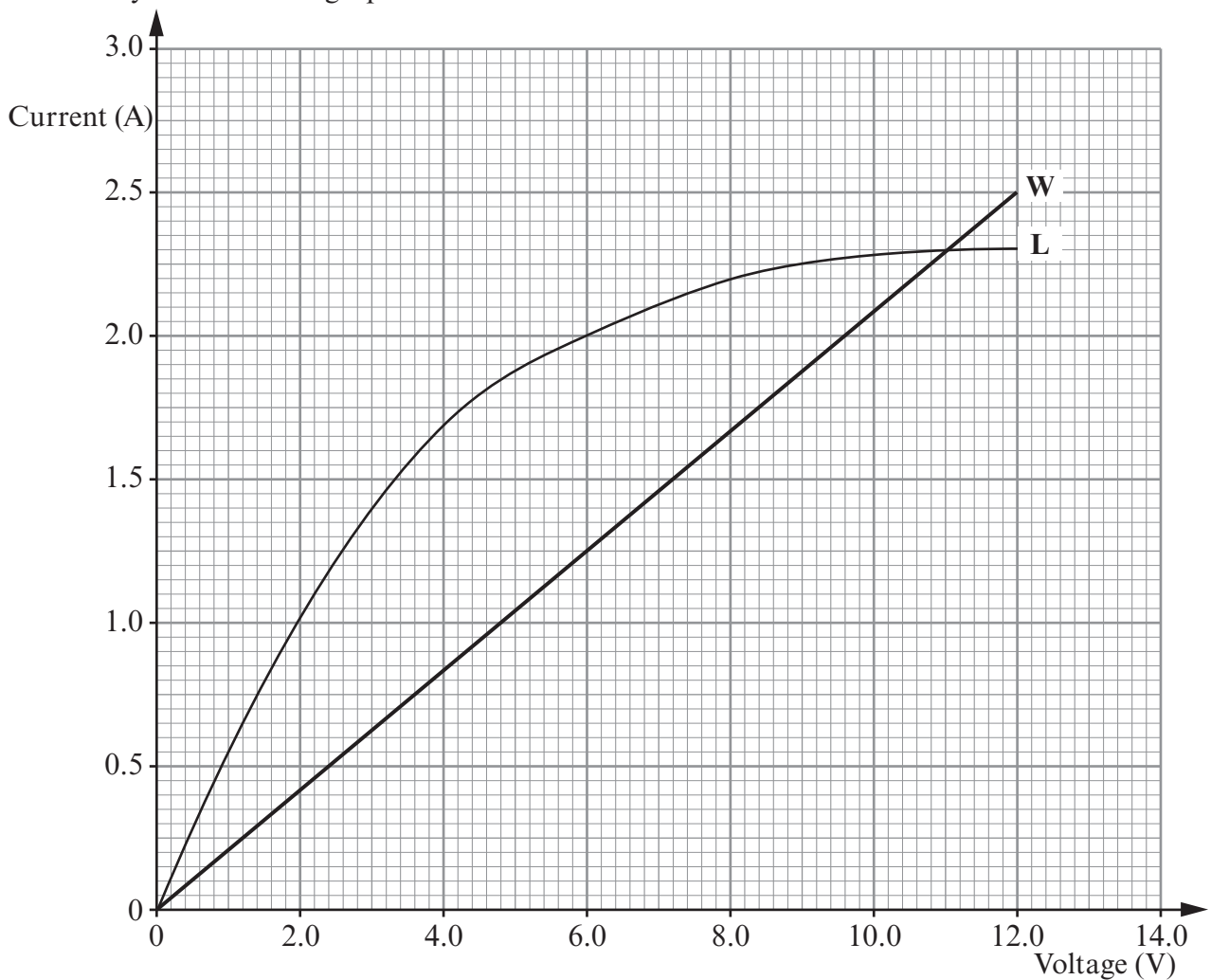

(a) (i) Use the graph to find the current through the lamp when the voltmeter reading is 6 V. [1]

Current = A

(ii) Using an equation from page 2, calculate the resistance of the lamp at 6 V. [2]

Resistance = Ω

(iii) Find the current through ammeter A_1 at 6 V. [1]

Current = A

(b) The voltage supply in the diagram is increased from 6 V to 12 V.

(i) Compare the resistances of the lamp and wire at 12 V. [1]

.....

(ii) Give a reason for your answer. [1]

.....

.....

.....

(c) "As the voltage is increased from 0 V to 12 V, the power of the wire is not always less than the power of the lamp." Explain why this statement is true. [2]

.....

.....

.....

.....

4473
02/00/05

8



2. A smoke detector works as follows:

- It uses a radioactive source that emits alpha particles.
- The alpha particles ionise the air inside the detector causing an electric current.
- Any smoke getting into the detector absorbs the alpha particles and changes the current.
- The change in current sets off the alarm.

(a) (i) What is an alpha particle? [1]

(ii) Explain why the detector would not work if the radioactive source emitted gamma rays only. [2]

.....
.....
.....
.....

(iii) Explain why, in normal use, the radioactive source in the detector is not a risk to human health. [2]

.....
.....
.....
.....

(b) Americium-241 has a half-life of 432 years. Curium-242 has a half-life of 160 days. Both isotopes are alpha emitters.

(i) Explain why Americium-241 is more suitable for use in the smoke detector than Curium-242. [2]

.....
.....
.....



(ii) An average smoke detector contains about 0.4 micrograms (μg) of Americium-241 which has an initial activity of 52 000 units.

(I) Name the unit of activity. [1]

(II) Calculate how long it will take for the activity to drop to 26 000 units. [2]

Time = years

(III) Calculate the mass of Americium-241 remaining after 864 years. [2]

Mass remaining = μg

12

4473
02/00/07

0 7

3. The government is considering increasing the motorway speed limit from 70 miles per hour (mph) to 80 mph. Standard thinking distances and braking distances for a variety of speeds are given in the table below. They apply to an alert driver on a dry day.

Speed (mph)	Thinking Distance (m)	Braking Distance (m)	Total Stopping Distance (m)
60	18	55	73
70	21	75	
80	24	97.5	

Discuss the advantages and disadvantages for taking a journey of 280 miles at 80 mph compared with 70 mph.

Include in your answer information from the table above and your knowledge on the topic.

You should use the equation: $time = \frac{distance}{speed}$ to help in part of your answer.

[6 QWC]

.....
.....
.....
.....
.....
.....
.....
.....
.....
.....
.....
.....
.....
.....
.....
.....
.....
.....
.....



4. A car of mass 1 500 kg, travelling at 15 m/s has its speed reduced to 5 m/s when it travels 7.5 m through a pile of sand in the road.

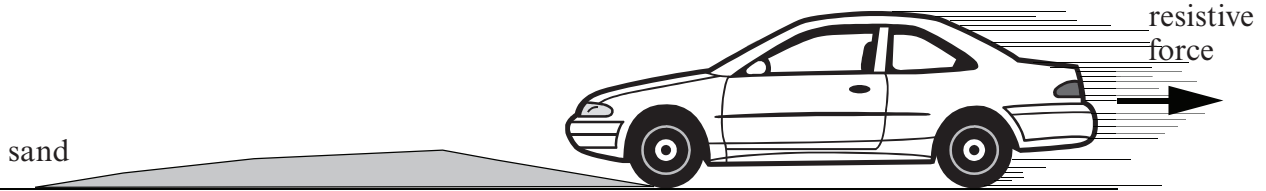

- (a) Use an equation from page 2 to calculate the loss of kinetic energy of the car. [3]

Loss in kinetic energy =

- (b) Use your answer to part (a) along with an equation from page 2 to find the (mean) resistive force produced by the sand during the collision. [3]

Resistive force = N

- (c) Write down the value of the horizontal force that acts on the **sand** in this collision. [1]

Force on the sand = N

7



5. A train of mass 80 000 kg leaves a station **A** and arrives at another station **D**. Its journey is shown on the velocity-time graph below.

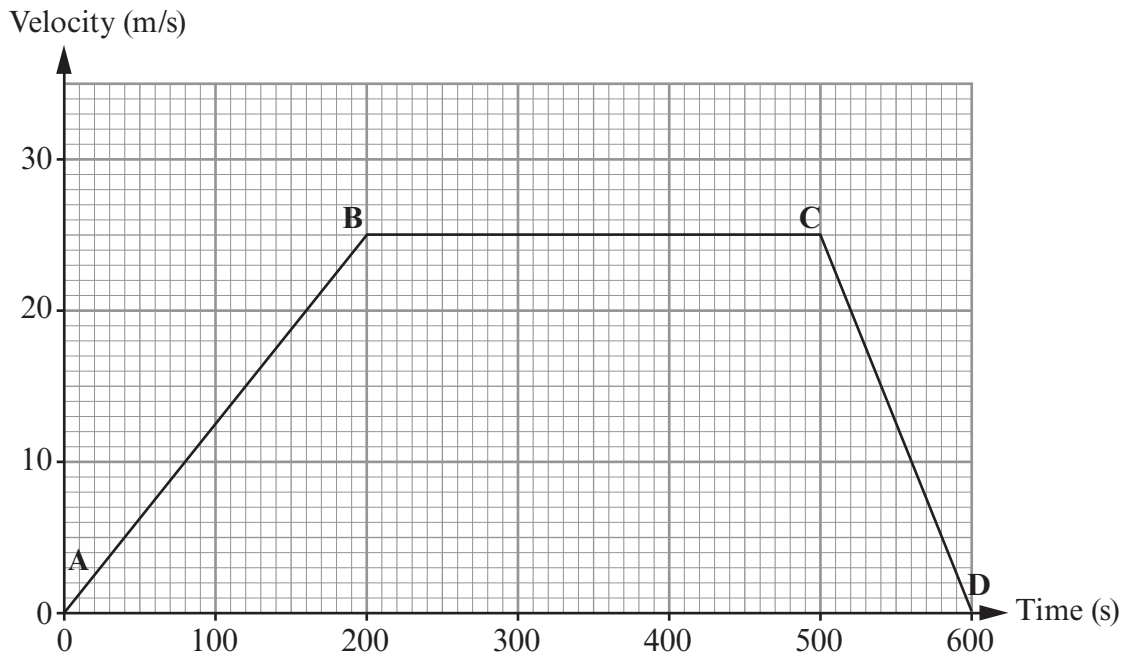

- (a) Describe the motion from **A** to **D** giving as much detail as possible. [3]

.....

.....

.....

.....

.....

.....

.....

- (b) (i) Use the graph and equations from page 2 to calculate the resultant force acting on the train when it was accelerating. [3]

Resultant force = N



- (ii) Explain how the size of the resultant force acting on the train during its deceleration compares to your answer in (b)(i). [3]

.....

.....

.....

.....

- (c) (i) Use the graph and equation from page 2 to calculate the distance from station A to station D. [3]

Distance from A to D = m

- (ii) Use your answer to (c)(i) and an equation from page 2 to calculate the mean speed of the train. [2]

Mean speed = m/s

- (iii) The mean speed for the journey is shown as a dotted line on the graph below.

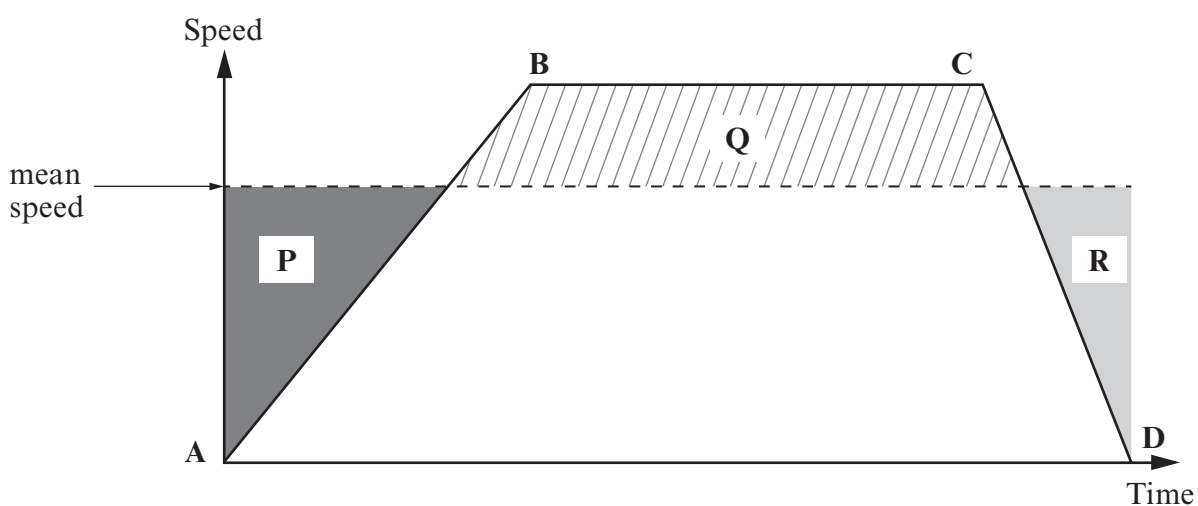

Write down how the three shaded areas P, Q and R are related mathematically. [1]

.....

.....



6. (a) Deuterium, ${}^2_1\text{H}$, is an isotope of hydrogen.
Explain what the term "isotope" means. [2]

.....

.....

.....

.....

(b) A fusion reaction can occur when two deuterium nuclei, ${}^2_1\text{H}$, collide at high speed to produce a helium nucleus (He) and release a neutron.

Explain the importance of this reaction along with its benefits and the difficulties in achieving it in a controlled manner. Your answer should include a balanced nuclear equation. [6 QWC]

.....

.....

.....

.....

.....

.....

.....

.....

.....

.....

.....

.....

.....

.....

.....

.....

.....

.....

.....

.....

.....

.....

.....

.....

.....

8



7. Two filament lamps, X and Y, are connected in series. Lamp Y is brighter than lamp X.

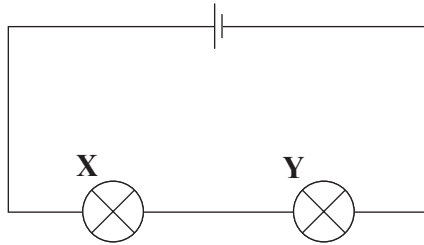

Choose and write down an equation from page 2 to explain why lamp Y is brighter than lamp X. [Hint: consider power] [4]

.....

.....

.....

.....

.....

.....

.....

.....

4

END OF PAPER



BLANK PAGE

**PLEASE DO NOT WRITE
ON THIS PAGE**

