

| | | |
|-------------|---------------|------------------|
| Surname | Centre Number | Candidate Number |
| Other Names | | 0 |



GCSE

4462/01



W15-4462-01

SCIENCE A/CHEMISTRY

CHEMISTRY 1

FOUNDATION TIER

A.M. TUESDAY, 13 January 2015

1 hour

| For Examiner's use only | | |
|-------------------------|--------------|--------------|
| Question | Maximum Mark | Mark Awarded |
| 1. | 4 | |
| 2. | 7 | |
| 3. | 6 | |
| 4. | 6 | |
| 5. | 8 | |
| 6. | 5 | |
| 7. | 8 | |
| 8. | 10 | |
| 9. | 6 | |
| Total | 60 | |

4462
010001

ADDITIONAL MATERIALS

In addition to this paper you will need a calculator and a ruler.

INSTRUCTIONS TO CANDIDATES

Use black ink or black ball-point pen. Do not use gel pen or correction fluid.

Write your name, centre number and candidate number in the spaces at the top of this page.

Answer **all** questions.

Write your answers in the spaces provided in this booklet.

If you run out of space, use a standard 4-page continuation booklet. Number the question(s) clearly and put your continuation booklet in this question-and-answer booklet. No other style of answer booklet should be used.

INFORMATION FOR CANDIDATES

The number of marks is given in brackets at the end of each question or part-question.

You are reminded of the necessity for good English and orderly presentation in your answers.

Assessment will take into account the quality of written communication (QWC) in your answer to question 9.





The Periodic Table is printed on the back cover of the examination paper and the formulae for some common ions on the inside of the back cover.



JAN1544620101

Answer all questions.

1. (a) Draw lines to match each diagram below with the correct description. One has been done for you. [2]

| Diagram | Description |
|---|-------------------------|
|  | molecule of a compound |
|  | molecule of an element |
|  | mixture of two elements |
|  | atom |



(b) The following diagram shows an atom.

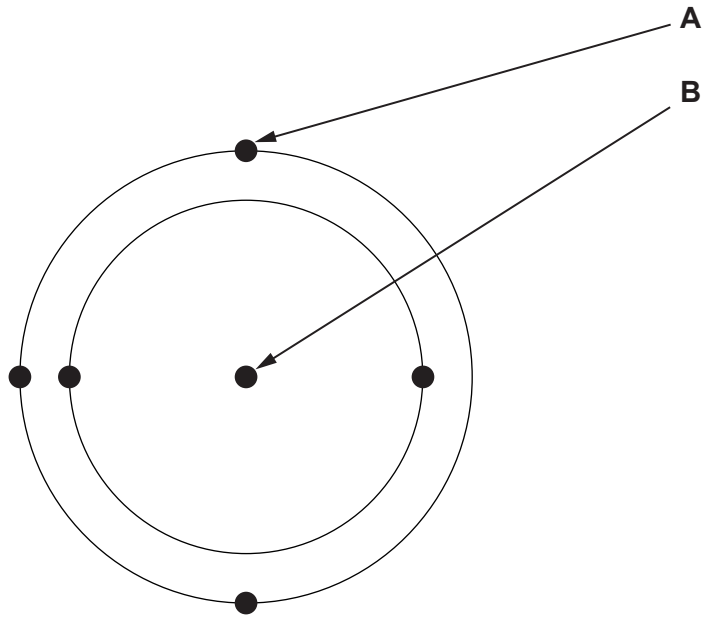

The box below contains some words that could be used in a description of the atom.

| | | |
|----------|----------|----------|
| neutral | electron | positive |
| negative | nucleus | orbit |

Use only words from the box to complete the table.

[2]

| | Name | Charge |
|--------|-------|--------|
| part A | | |
| part B | | |

4462
010003

| |
|---|
| |
| 4 |



2. It is believed that the Earth's original atmosphere was produced from volcanoes. The following tables show the gases given out by a volcano and the gases present in today's atmosphere.

| Gas | Amount given out by a volcano (%) |
|----------------|-----------------------------------|
| water vapour | 79.0 |
| carbon dioxide | 12.0 |
| sulfur dioxide | 6.5 |
| nitrogen | 1.5 |
| others | 1.0 |

| Gas | Amount present in today's atmosphere (%) |
|-------------------------------|--|
| nitrogen | 78.0 |
| oxygen | 21.0 |
| carbon dioxide | 0.04 |
| others including water vapour | 0.9 |

- (a) Using the information in the tables describe **three** differences between the gases given out by a volcano and today's atmosphere. [3]

.....

.....

.....

.....

- (b) Levels of carbon dioxide and oxygen have remained approximately constant for 3500 million years. Name the **two natural** processes that have allowed this to happen. [2]

..... and

- (c) Human activity pollutes the atmosphere which leads to environmental problems. Name the gases responsible for the following problems. [2]

Global warming

Acid rain



3. (a) Complete the following table that shows information about some compounds. [4]

| Compound | Formula | Number of atoms present | Elements present |
|--------------------|-----------------|-------------------------|------------------------|
| aluminium chloride | AlCl_3 | 4 | aluminium and chlorine |
| | CaO | 2 | calcium and oxygen |
| copper(II) sulfide | CuS | | and |
| sodium oxide | | 3 | sodium and oxygen |

(b) The following diagram represents a molecule of ethanol, $\text{C}_2\text{H}_5\text{OH}$.



Give the **names** of the atoms represented by the following symbols. [2]

●

○

◐



4. The following table shows the pH of some common substances.

| Substance | pH |
|------------------|------|
| limewater | 10.5 |
| saliva | 6.4 |
| lemon juice | 2.2 |
| orange juice | 2.6 |
| milk of magnesia | 10.0 |

(a) Use only information from the table to answer parts (i) and (ii).

(i) Name the strongest acid. [1]

.....

(ii) Name the substance closest to being neutral. [1]

.....

(b) Milk of magnesia is used to treat indigestion. It contains magnesium hydroxide which reacts with excess hydrochloric acid in the stomach.

(i) Complete the following word equation to show the products formed. [2]



(ii) Another indigestion remedy contains calcium carbonate. Name the gas produced when calcium carbonate reacts with hydrochloric acid and state how this gas can be identified. [2]

Gas produced

How this gas can be identified

.....



BLANK PAGE

**PLEASE DO NOT WRITE
ON THIS PAGE**

4462
010007



07

5. (a) Crude oil is a mixture of hydrocarbons.

(i) State what is meant by a *hydrocarbon*. [1]

.....

.....

(ii) Describe how crude oil was formed. [2]

.....

.....

(b) The following pie chart shows the mass in kg of each fraction present in 200 kg of crude oil.

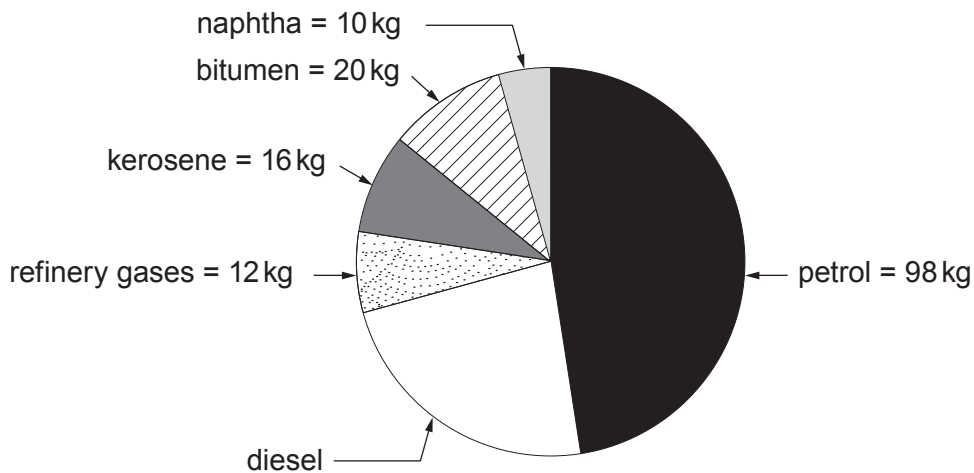

(i) Name the **two** fractions that are **not** used as fuels. [1]

..... and

(ii) Calculate the percentage of diesel present in this crude oil. [2]

Percentage of diesel = %



(iii) The names of some processes are given in the box below.

cracking

polymerisation

distillation

electrolysis

Name the process by which

I. large hydrocarbon molecules can be made into smaller molecules, [1]

.....

II. small reactive molecules can be joined together to produce long chains. [1]

.....

8

4462
010009



6. Fractional distillation of liquid air is similar to that of crude oil.

The diagram below shows the apparatus used to separate the gases in air.

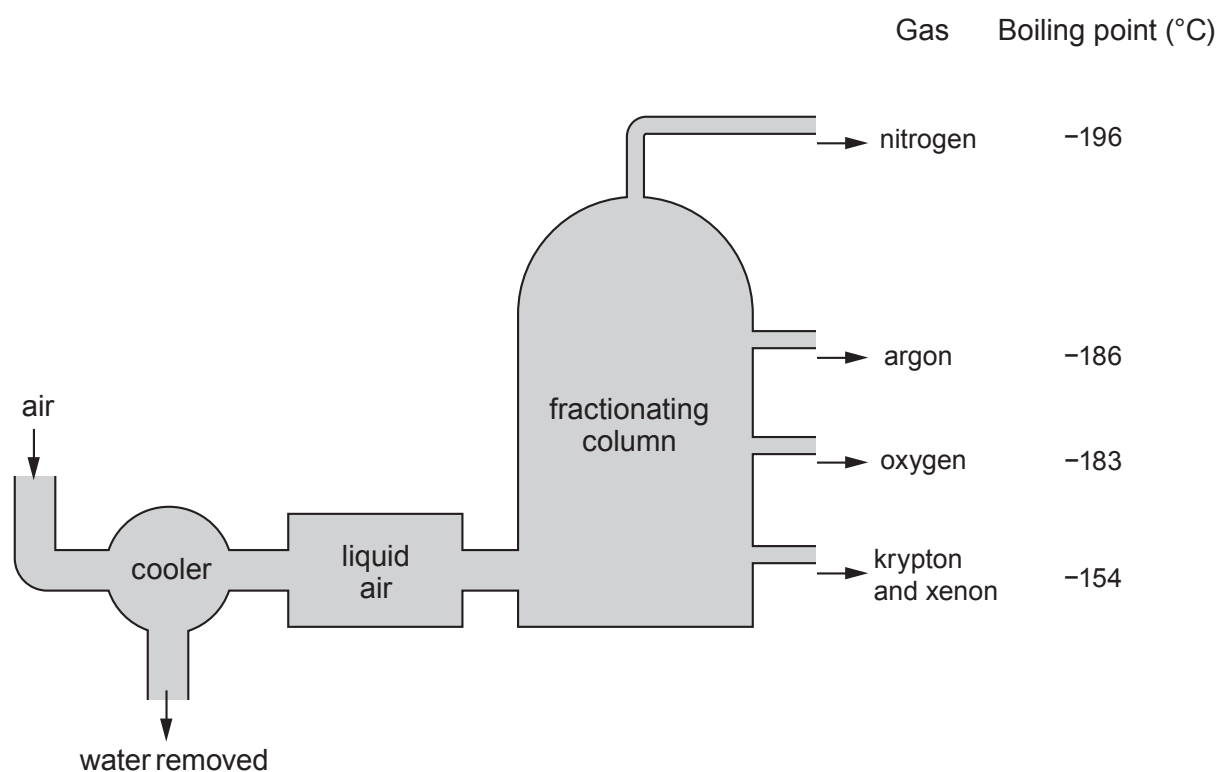

(a) From the diagram, name the gas that has the lowest boiling point. [1]

.....

(b) Suggest a reason why krypton and xenon cannot be separated by this process. [1]

.....

.....

(c) Air is cooled to -200°C . Give the state (solid, liquid or gas) of the water removed at this temperature and give a reason for your answer. [2]

State of water removed

Reason

.....

(d) Argon is used in light bulbs to prevent the filament from burning. State what property of argon makes it useful for this purpose. [1]

.....



BLANK PAGE

**PLEASE DO NOT WRITE
ON THIS PAGE**



7. (a) The following chart shows the melting points and boiling points of the elements in Group 7.

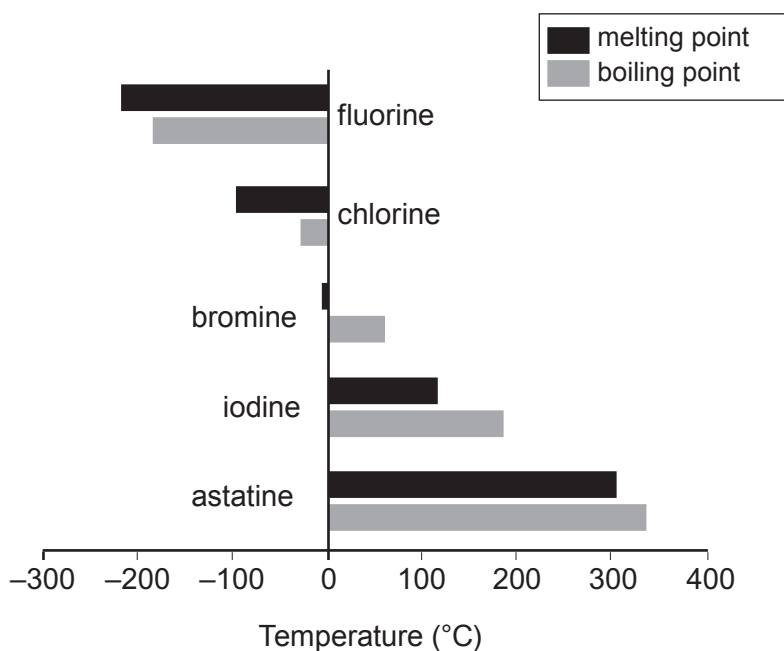

Give the state (solid, liquid or gas) of bromine at room temperature giving the reasons for your answer. [2]

.....

.....

.....

- (b) The following table shows the observations made when some Group 7 elements react with hydrogen.

| Element | Observations |
|----------|------------------------------|
| chlorine | explodes in sunlight |
| bromine | violent reaction when heated |
| iodine | reacts when heated strongly |

Describe the trend in reactivity within the group and use this trend to predict how astatine would react with hydrogen. [2]

.....

.....



- (c) Group 7 elements also react with iron. Balance the following symbol equation that shows the reaction of iron and fluorine. [1]



- (d) Chlorine and iodine can be extracted from seawater by electrolysis.

- (i) Balance the following electrode equation showing how chlorine is formed. [1]

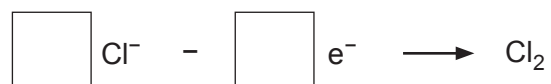

- (ii) Chlorides make up 55% of the salts present in seawater and it is therefore economically viable to extract chlorine from seawater. Suggest a reason why iodine is no longer extracted in this way. [1]
-
-

- (iii) State the property of chlorine and iodine that make them suitable for use in disinfectants and antiseptics. [1]
-



8. (a) When a mixture of iron(III) oxide and aluminium powder (thermite) is heated in the apparatus shown below, there is a violent reaction. There is a bright flame, sparks are produced and molten iron is formed.

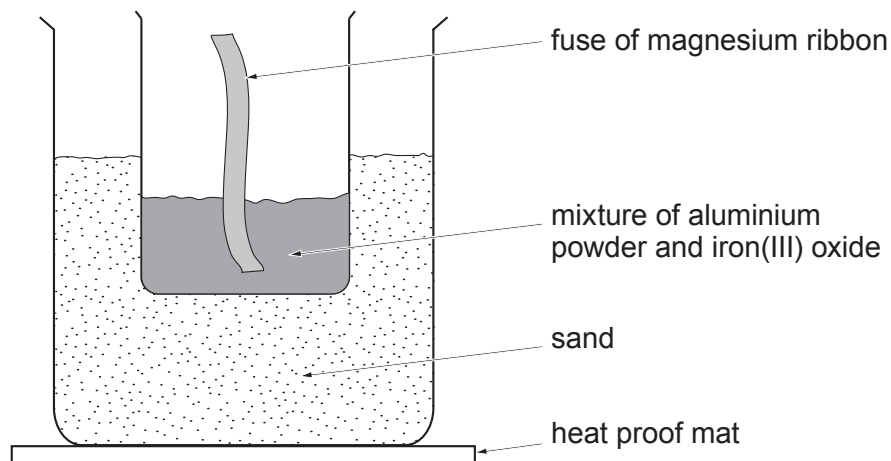

- (i) Write a **word** equation for the reaction taking place. [2]

..... + → +

- (ii) Explain this reaction in terms of reactivity. [2]

.....

- (iii) State how the observations would be different if the mixture were replaced with a mixture of copper powder and aluminium oxide. [1]

.....



(b) Iron is extracted from its ore in a blast furnace.

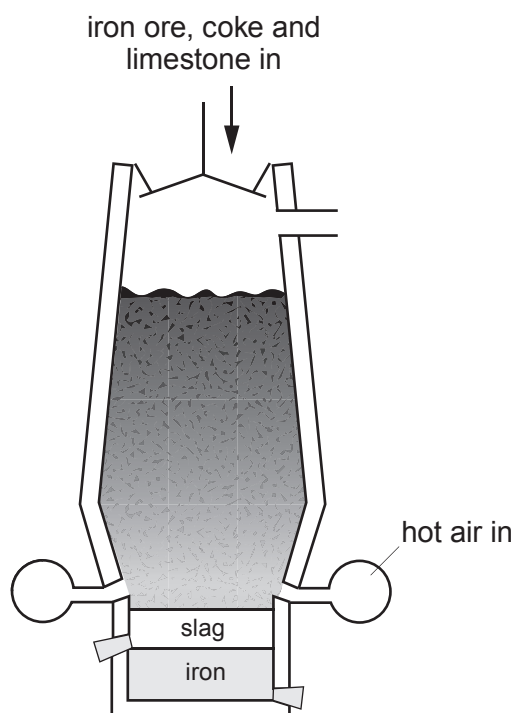

(i) State the purpose of the following raw materials.

[3]

Iron ore

.....
.....

Coke

.....
.....

Limestone

.....
.....



(ii) The following equation shows the reaction taking place.



I. Balance the equation. [1]

II. Iron(III) oxide is reduced during the reaction. Give the meaning of *reduction*. [1]

.....
.....

| |
|----|
| |
| 10 |



BLANK PAGE

**PLEASE DO NOT WRITE
ON THIS PAGE**



FORMULAE FOR SOME COMMON IONS

| POSITIVE IONS | | NEGATIVE IONS | |
|---------------|------------------|---------------|--------------------|
| Name | Formula | Name | Formula |
| Aluminium | Al^{3+} | Bromide | Br^- |
| Ammonium | NH_4^+ | Carbonate | CO_3^{2-} |
| Barium | Ba^{2+} | Chloride | Cl^- |
| Calcium | Ca^{2+} | Fluoride | F^- |
| Copper(II) | Cu^{2+} | Hydroxide | OH^- |
| Hydrogen | H^+ | Iodide | I^- |
| Iron(II) | Fe^{2+} | Nitrate | NO_3^- |
| Iron(III) | Fe^{3+} | Oxide | O^{2-} |
| Lithium | Li^+ | Sulfate | SO_4^{2-} |
| Magnesium | Mg^{2+} | | |
| Nickel | Ni^{2+} | | |
| Potassium | K^+ | | |
| Silver | Ag^+ | | |
| Sodium | Na^+ | | |
| Zinc | Zn^{2+} | | |





PERIODIC TABLE OF ELEMENTS

1 2

Group

3

4

5

6

7

0

| |
|--------------------|
| 1 H Hydrogen |
|--------------------|

| | | | | | | | | | | | | | | | | | | | | | | | | | | | | | | | | | | | | | | | | | | | | | | | | | | | | | | | | | | | | | | | | | | | | | | | | | | | | | | | | | | | | | | | | | | | | | | | | | | | | | | | | | | | | | | | | | | | | | | | | | | | | | | | | | | | | | | | |
|----------------------|-----------------------|----------------------|-----------------------|--------------------------|------------------------|------------------------|-----------------------|-----------------------|-----------------------|-----------------------|-------------------------|-------------------------|----------------------|--------------------------|-----------------------|-------------------------|----------------------------|----------------------|-------------------------|-----------------------|----------------------|--------------------------|---------------------------|--------------------------|--------------------------|-----------------------|------------------------|------------------------|--------------------------|-------------------------|------------------------|--------------------------|------------------------|-----------------------|--------------------------|--------------------------|-------------------------|--------------------------|------------------------|--------------------------|--------------------------|--------------------------|--------------------------|--------------------------|--------------------------|--------------------------|--------------------------|--------------------------|--------------------------|--------------------------|--------------------------|--------------------------|--------------------------|--------------------------|--------------------------|--------------------------|--------------------------|--------------------------|--------------------------|--------------------------|--------------------------|--------------------------|--------------------------|--------------------------|--------------------------|--------------------------|--------------------------|--------------------------|--------------------------|--------------------------|--------------------------|--------------------------|--------------------------|--------------------------|--------------------------|--------------------------|--------------------------|--------------------------|--------------------------|--------------------------|--------------------------|--------------------------|--------------------------|--------------------------|--------------------------|--------------------------|--------------------------|--------------------------|--------------------------|--------------------------|--------------------------|--------------------------|--------------------------|--------------------------|--------------------------|--------------------------|--------------------------|--------------------------|--------------------------|--------------------------|--------------------------|--------------------------|--------------------------|--------------------------|--------------------------|--------------------------|--------------------------|--------------------------|--------------------------|--------------------------|--------------------------|--------------------------|--------------------------|--------------------------|--------------------------|--------------------------|--------------------------|--------------------------|--------------------------|--------------------------|--------------------------|--------------------------|--------------------------|--------------------------|--------------------------|--------------------------|--------------------------|--------------------------|--------------------------|--------------------------|--------------------------|--------------------------|--------------------------|--------------------------|--------------------|
| 7 Li Lithium | 9 Be Beryllium | 11 Na Sodium | 12 Mg Magnesium | 19 K Potassium | 20 Ca Calcium | 21 Sc Scandium | 22 Ti Titanium | 23 V Vanadium | 24 Cr Chromium | 25 Mn Manganese | 26 Fe Iron | 27 Co Cobalt | 28 Ni Nickel | 29 Cu Copper | 30 Zn Zinc | 31 Ga Gallium | 32 Ge Germanium | 33 As Arsenic | 34 Se Selenium | 35 Br Bromine | 36 Kr Krypton | | | | | | | | | | | | | | | | | | | | | | | | | | | | | | | | | | | | | | | | | | | | | | | | | | | | | | | | | | | | | | | | | | | | | | | | | | | | | | | | | | | | | | | | | | | | | | | | | | | | | | | | | | | | | | | | | | |
| 3 Li Lithium | 4 Be Beryllium | 11 Na Sodium | 12 Mg Magnesium | 19 K Potassium | 20 Ca Calcium | 21 Sc Scandium | 22 Ti Titanium | 23 V Vanadium | 24 Cr Chromium | 25 Mn Manganese | 26 Fe Iron | 27 Co Cobalt | 28 Ni Nickel | 29 Cu Copper | 30 Zn Zinc | 31 Ga Gallium | 32 Ge Germanium | 33 As Arsenic | 34 Se Selenium | 35 Br Bromine | 36 Kr Krypton | | | | | | | | | | | | | | | | | | | | | | | | | | | | | | | | | | | | | | | | | | | | | | | | | | | | | | | | | | | | | | | | | | | | | | | | | | | | | | | | | | | | | | | | | | | | | | | | | | | | | | | | | | | | | | | | | | |
| 37 Rb Rubidium | 38 Sr Strontium | 39 Y Yttrium | 40 Zr Zirconium | 41 Nb Niobium | 42 Mo Molybdenum | 43 Tc Technetium | 44 Ru Ruthenium | 45 Rh Rhodium | 46 Pd Palladium | 47 Ag Silver | 48 Cd Cadmium | 49 In Indium | 50 Sn Tin | 51 Sb Antimony | 52 Te Tellurium | 53 I Iodine | 54 Xe Xenon | 55 Cs Caesium | 56 Ba Barium | 57 La Lanthanum | 58 Ce Cerium | 59 Pr Praseodymium | 60 Nd Neodymium | 61 Pm Promethium | 62 Sm Samarium | 63 Eu Europium | 64 Gd Gadolinium | 65 Tb Terbium | 66 Dy Dysprosium | 67 Ho Holmium | 68 Er Erbium | 69 Tm Thulium | 70 Yb Ytterbium | 71 Lu Lutetium | 72 Hf Hafnium | 73 Ta Tantalum | 74 W Tungsten | 75 Re Rhenium | 76 Os Osmium | 77 Ir Iridium | 78 Pt Platinum | 79 Au Gold | 80 Hg Mercury | 81 Tl Thallium | 82 Pb Lead | 83 Bi Bismuth | 84 Po Polonium | 85 At Astatine | 86 Rn Radon | | | | | | | | | | | | | | | | | | | | | | | | | | | | | | | | | | | | | | | | | | | | | | | | | | | | | | | | | | | | | | | | | | | | | | | | | | | | | | | | | | | | | | |
| 87 Fr Francium | 88 Ra Radium | 89 Ac Actinium | 90 Th Thorium | 91 Pa Protactinium | 92 U Uranium | 93 Np Neptunium | 94 Pu Plutonium | 95 Am Americium | 96 Cm Curium | 97 Bk Berkelium | 98 Cf Californium | 99 Es Einsteinium | 100 Fm Fermium | 101 Md Mendelevium | 102 No Nobelium | 103 Lr Lawrencium | 104 Rf Rutherfordium | 105 Db Dubnium | 106 Sg Seaborgium | 107 Bh Bohrium | 108 Hs Hassium | 109 Mt Meitnerium | 110 Ds Darmstadtium | 111 Rg Roentgenium | 112 Cn Copernicium | 113 Nh Nihonium | 114 Fl Flerovium | 115 Mc Moscovium | 116 Lv Livermorium | 117 Ts Tennessine | 118 Og Oganesson | 119 Uue Ununennium | 120 Uub Unbibium | 121 Uut Untrium | 122 Uuq Unquadrium | 123 Uuq Unquadrium | 124 Uup Unpentium | 125 Uuq Unquadrium | 126 Uuh Unhexium | 127 Uuq Unquadrium | 128 Uuq Unquadrium | 129 Uuq Unquadrium | 130 Uuq Unquadrium | 131 Uuq Unquadrium | 132 Uuq Unquadrium | 133 Uuq Unquadrium | 134 Uuq Unquadrium | 135 Uuq Unquadrium | 136 Uuq Unquadrium | 137 Uuq Unquadrium | 138 Uuq Unquadrium | 139 Uuq Unquadrium | 140 Uuq Unquadrium | 141 Uuq Unquadrium | 142 Uuq Unquadrium | 143 Uuq Unquadrium | 144 Uuq Unquadrium | 145 Uuq Unquadrium | 146 Uuq Unquadrium | 147 Uuq Unquadrium | 148 Uuq Unquadrium | 149 Uuq Unquadrium | 150 Uuq Unquadrium | 151 Uuq Unquadrium | 152 Uuq Unquadrium | 153 Uuq Unquadrium | 154 Uuq Unquadrium | 155 Uuq Unquadrium | 156 Uuq Unquadrium | 157 Uuq Unquadrium | 158 Uuq Unquadrium | 159 Uuq Unquadrium | 160 Uuq Unquadrium | 161 Uuq Unquadrium | 162 Uuq Unquadrium | 163 Uuq Unquadrium | 164 Uuq Unquadrium | 165 Uuq Unquadrium | 166 Uuq Unquadrium | 167 Uuq Unquadrium | 168 Uuq Unquadrium | 169 Uuq Unquadrium | 170 Uuq Unquadrium | 171 Uuq Unquadrium | 172 Uuq Unquadrium | 173 Uuq Unquadrium | 174 Uuq Unquadrium | 175 Uuq Unquadrium | 176 Uuq Unquadrium | 177 Uuq Unquadrium | 178 Uuq Unquadrium | 179 Uuq Unquadrium | 180 Uuq Unquadrium | 181 Uuq Unquadrium | 182 Uuq Unquadrium | 183 Uuq Unquadrium | 184 Uuq Unquadrium | 185 Uuq Unquadrium | 186 Uuq Unquadrium | 187 Uuq Unquadrium | 188 Uuq Unquadrium | 189 Uuq Unquadrium | 190 Uuq Unquadrium | 191 Uuq Unquadrium | 192 Uuq Unquadrium | 193 Uuq Unquadrium | 194 Uuq Unquadrium | 195 Uuq Unquadrium | 196 Uuq Unquadrium | 197 Uuq Unquadrium | 198 Uuq Unquadrium | 199 Uuq Unquadrium | 200 Uuq Unquadrium | 201 Uuq Unquadrium | 202 Uuq Unquadrium | 203 Uuq Unquadrium | 204 Uuq Unquadrium | 205 Uuq Unquadrium | 206 Uuq Unquadrium | 207 Uuq Unquadrium | 208 Uuq Unquadrium | 209 Uuq Unquadrium | 210 Uuq Unquadrium | 211 Uuq Unquadrium | 212 Uuq Unquadrium | 213 Uuq Unquadrium | 214 Uuq Unquadrium | 215 Uuq Unquadrium | 216 Uuq Unquadrium | 217 Uuq Unquadrium | 218 Uuq Unquadrium | 219 Uuq Unquadrium | 220 Uuq Unquadrium | 221 Uuq Unquadrium | 222 Rn Radon |

Key:

